

VOCE

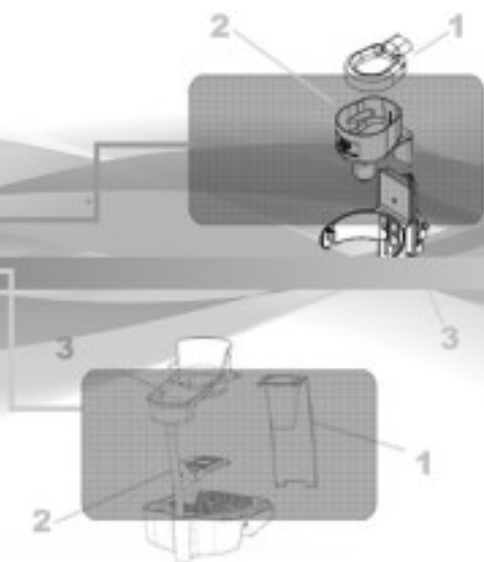

Technical Manual

EC Declaration of Conformity

We Crane Merchandising Systems (UK),

Of Pipsmore Park, Bumpers Farm Industrial Estate, Chippenham, Wiltshire, UK, SN14 6NQ

Declare that:

Type of Equipment: Beverage Vending Machine

Model Name: VOCE

Has been designed and manufactured to comply with all essential requirements of the following Regulations/Directives:

73/23/EEC 93/68/EEC 2006/95/EEC The Low Voltage Directive and its amending directives

89/336/EEC 91/263/EEC 92/31/EEC 93/68/EEC 2004/108/EEC The Electromagnetic Compatibility Directive and its amending directives

REG. (EC) 1935/2004 on materials and articles intended to come into contact with food
REG. (EC) 1895/2005 on the restriction of use of certain epoxy derivatives in materials and articles intended to come into contact with food.

DIR. 2002/72 EC relating to plastic materials and articles intended to come into contact with foodstuffs.

Tests have been performed by accredited certification bodies in accordance to the following specifications:

Low Voltage Directive: EN 60335-1: 2002 + A1+ A11, EN 60335-2-75: 2004+ A1
EN ISO 11201 + EN ISO 3744

EMC Directive: EN 55014-1:2000+A1+A2, EN 55014-2:1997+A1,
EN 61000-3-2: 2000+A2, EN 61000-3-3:1995+A1+A2, EN 61000-4-4,
EN 61000-4-5, EN 61000-4-6, EN 61000-4-11, EN 61000-4-2,
EN 50366:2003 +A1

HMM: Contribution of heavy metal migrants from different parts of the circuits of machine under in use conditions according to EU directives and guidelines.

With regard to hygiene for foodstuffs in location, the operator must comply with 852/2004/EEC which lays out the general and specific hygiene rules to ensure a high level of consumer protection with regard to food safety.

Date: 03 January 2012

Legal Representative

Signature:

The following Symbol is used throughout this Manual:



Safety First! Take care, risk of personal injury.

Crane Merchandising Systems accepts no responsibility for damage caused to the equipment through misinterpretation or misuse of the information contained in this manual.

© Copyright 2012 Crane Merchandising Systems

Introduction

This manual provides you with guidance on the installation, daily operation and basic maintenance of your VOCE freestanding vending machine. Crane Merchandising Systems always recommend that a trained technician service its equipment.

Crane Merchandising Systems is committed to continuous product improvement. This means that the information within this document, although correct at time of publication, is for guidance only and may be subject to change without prior notice.

Important Safeguards

Always follow these basic safety precautions when operating or maintaining your machine:

1. Ensure that you and anyone who operates or maintains your machine have this manual available for quick and easy reference, read all instructions carefully before commencing work.
2. **Beware of Electricity** Certain maintenance operations require your machine to remain connected and switched on. Only trained personnel should carry out these routines, and independently of all other operations. Observation of safe working practices in accordance with current regulations is necessary at all times.



Important! Unless otherwise specified, always disconnect your machine from the electricity supply before commencing work.

3. Servicing the Heater Tank/Esspresso pressurised water system



Important! Water in this machine can exceed 99°C. Water at this temperature can cause severe injury. Espresso machines may be fitted with a pressurised water system, under no circumstance should this be dismantled other than by a full trained engineer.

4. Do not operate your machine if any part is damaged until a service technician has carried out necessary repairs and ensured that it is safe.
5. Beware of moving components when servicing the machine.
6. Allow your machine to cool before handling or moving.
7. Never immerse your machine in water or any other liquid and never clean it with a water jet.
8. In machines fitted with carbonator units the CO2 bottle is filled with gas at up to 800psi and MUST be secured in an upright position. In the event of a leak, ventilate the area in the vicinity

9. Ensure that you are familiar and adhere to the most recent Health and Safety at Work and Electricity at Work Regulations.



Important! This appliance is not intended for use by persons (including children and the infirm) with reduced physical, sensory or mental capabilities, or lack of experience and knowledge, unless they have been given supervision or instruction concerning use of the appliance by a person responsible for their safety. Children should be supervised to ensure that they do not play with the appliance.

Your VOCE machine is for indoor use only and because it is a beverage machine, should be sited in a clean and hygienic area.

Table of Contents

- Section 1 - Machine Specification 1
 - 1.1 Specifications 1
 - 1.2 Water Filter 1
 - 1.3 External Features 2
 - 1.4 Internal Features 3
- Section 2 - Installation (Engineer’s Procedure) 5
 - 2.1 Siting Your Machine 5
 - 2.2 Connecting the Water Supply 5
 - 2.3 Connecting the Electric Supply 6
 - 2.4 Commissioning Procedure 6
 - 2.5 Setting Up the Carbonator Unit (Where Fitted) 9
 - 2.6 Warranty Card 9
- Section 3 - How To Vend A Drink 11
 - 3.1 Selecting A Drink - Build a Drink 11
 - 3.2 Selecting A Drink - Cold Drink Selection 13
 - 3.3 Selecting A Drink - Keyless Jug / Free Vend Transition 13
 - 3.4 Replacing/Updating Drink Selection Decals 15
- Section 4 - Service Keypad Functions 17
- Section 5 - Programming Mode 21
 - 5.1 Drink Selection Keypad 21
 - 5.2 Menu Display 22
 - 5.3 Accessing the Programming Mode 22
 - 5.4 View Diagnostics 24
- Section 6 - Engineer Program 25
 - 6.1 Data Recall Menu 25
 - 6.2 Diagnostic Menu 30
 - 6.3 Test 30
 - 6.4 Price 37
 - 6.5 Product Configuration 39
 - 6.6 Free Vend 49
 - 6.7 Coins In/Out 49

6.8 System Settings	50
6.9 Security Codes	61
Section 7 - Technical Information	71
7.1 Water Services	71
7.2 Hot Water System	71
7.3 Ingredient Dispense	71
7.4 Mixing System	72
7.5 Moving Dispense Head	72
7.6 Cup Dispense Unit	72
7.7 Waste Level Probes	73
7.8 Oltre Brewer	73
7.9 CoEx Brewer (B2C Machines)	74
7.10 Power Supply Unit	74
7.11 Mains Filter	74
7.12 Coin Mechanism Transformer (Optional Extra)	74
7.13 Coin and Card/Key Systems	75
7.14 Change Giver	75
7.15 Card/Key System	75
Section 8 - B2C (Espresso) System	77
8.1 Example Vend	77
8.2 System Overview	77
Section 9 - Diagnostics and Maintenance Procedures	81
9.1Diagnostics	81
9.2 Heater Tank De-Scale Procedure	84
9.3 System Drain Down (B2C Machines)	84
9.4 CoEx Brewer/Bean Grinder Maintenance (B2C Machines)	87
Section 10 - Electrical/Electronics Information	93
Section 11 - Dispense Pipe Lengths	95
11.1 To Replace Pipes	95
Section 12 - Spare Parts	97
Exterior View	99
Interior View – Instant 8 Canister	100
Interior View – Single Freshbrew	101
Interior View – Double Freshbrew	102

Interior View – Triple Freshbrew	103
Interior View – Bean to Cup and Fresh Brew Tea and Roast and Ground Models.....	104
Dispense Area Components	105
Dispense Head Assembly.....	107
Keypad – 18 Button	108
Power Supply Assembly.....	109
Heater Tank Assembly	111
Cup Drop Unit Assembly.....	113
7 Stack Cup Drop Unit Assembly	115
Mixing System	117
Crane Mixing System	119
Oltre Brewer Fresh-Brew Tea and Fresh-Brew Coffee.....	121
CoEx® Module Assembly (B2C Machines)	123
CoEx® Brewer/Motor Assembly (B2C Machines)	125
CoEx® Module Assembly (B2C Machines)	127
CoEx® Additional Parts - B2C Module Assembly.....	128
Canister Assembly	131
Canister Assembly – Freshbrew Coffee	133
Canister Assembly – Bean Hopper (Round).....	134
Surevend™ Assembly.....	135
Extract System	136
Waste Bucket	137
Refrigeration Components	138
Additional Refrigeration Components – No Images	139
Fixings & Fasteners	140

Section 1 - Machine Specifications

1.1 Specifications

General

- Height1830 mm
- Width705 mm
- Depth790 mm
- Weight184 kg
- Cup Capacity *800 (7oz plastic squat)
 - 750 (7oz plastic tall)
 - 665 (7oz paper)
 - 650 (9oz plastic)
 - 575 (9oz paper)
 - 400 (12oz paper)

*Approximate and are for guidance only.

Electrical Services

- Voltage220 - 240 Volts
- AC Current13 Amp Fused
- Frequency50 Hz

Water Services

- Pressure200 Kpa (2 Bar) - 600 Kpa (6 Bar)
- Stopcock 15 mm BSP from rising main

All weights and dimensions are approximate and are for guidance only.

1.2 Water Filter

If your VOCE machine is fitted with a CoEx® B2C brewer, then it must be connected to the water supply via a scale inhibiting water filter. Crane Merchandising Systems recommend and supply the Brita AquaQuell, and Cuno range of water filters.

1.3 External Features

Key:

- | | | | |
|---|---------------------|----|---------------------|
| 1 | Upper Graphic Panel | 7 | LCD Display |
| 2 | Selection Decals | 8 | Selection Button |
| 3 | Door Lock | 9 | Coin Return Button |
| 4 | SureVend™ Sensor | 10 | Coin Entry |
| 5 | Kickplate | 11 | Coin Return |
| 6 | Adjustable Foot | 12 | Lower Graphic Panel |



1.4 Internal Features

Key:

- | | | | |
|---|------------------------|----|------------------------|
| 1 | Main Switch | 8 | Kick Plate |
| 2 | Spray Head | 9 | Service Keypad |
| 3 | Oltre Brewer (Coffee) | 10 | Cup Turret |
| 4 | Oltre Brewer (Tea) | 11 | Door Locking Mechanism |
| 5 | Mixing Station | 12 | Cup Catcher |
| 6 | Brewer Waste Container | 13 | Surevend™ Sensor |
| 7 | Waste Bucket | 14 | Drip Catcher Bracket |



Section 2 - Installation (Engineer's Procedure)



Important! It is essential that the personnel responsible for installing and servicing your machine, understand the following:

1. The installation and commissioning of your machine should only be carried out by a trained and authorised service technician.
2. All water and electrical services must be correctly and safely connected.
3. All covers must be replaced correctly and securely and your machine left in a safe condition.

2.1 Siting your Machine

1. Your machine is only suitable for indoor use, we recommend that it be situated in an area with an ambient temperature not below 10° C and not exceeding 30° C. Your machine should be located near the appropriate water and electrical services, refer to Section 1.1 Specifications.
2. Prior to placing your machine in its final location, ensure that there is sufficient access space available via passageways, stairs, lifts, etc.
3. To ensure adequate ventilation, 100 - 150 mm (4 - 6 inches) clearance must be allowed between the back of the cabinet and the wall.
4. Open the door using the key provided. Remove transit packing and installation kit. Check for visual signs of damage which may have occurred during transit. If your machine is damaged or any parts are missing, you must contact the supplier immediately.
5. Level your machine in both the front-to-back and side-to-side planes by adjusting the feet. Ensure that the door opens and closes easily and the lock operates correctly.

2.2 Connecting the Water Supply

1. Your machine should be situated within 1 metre of a drinking water supply from a rising main, terminating with a W.R.C. approved 15mm compression stop-tap.

N.B. The water supply should comply with both the Statutory Instrument No.1147 - "Water, England and Wales" and The Water Supply (Water Quality) Regulations 1989. Water pressure at the stop-tap must be within the limits 2 - 6 Bar (200 Kpa - 600 Kpa).

2. **Freshbrew & B2C Machines:** If your VOCE machine is fitted with an Oltre brewer, or CoEx® B2C brewer, then it must be connected to the water supply via a water filter. This filter must be of food grade quality and able to remove temporary hardness (scale), heavy metals (lead, copper, iron, and cadmium), chlorine and any organic pollutants/discolouration.

Crane Merchandising Systems recommend and supply the Brita AquaQuell water filter.



Warning! If your Freshbrew or B2C machine is connected to a water supply and used without a water filter as specified above, your warranty will be void.

3. Connect the flexi-hose supplied with your machine to the stopcock ensuring that the seal is fitted correctly. Flush the water supply before connecting the machine.
N.B. When connecting your machine to a water supply always use a new flexi-hose (such as the one supplied). Never re-use an existing hose.
4. Connect the hose to the inlet valve located on the rear of your machine. Ensure that the seal is correctly fitted. Ensure that all water supply fittings are tight.
5. Turn on the water supply at the stop tap and check for leaks. Prime the water filter (where fitted) following the instructions supplied by the filter manufacturer.

2.3 Connecting the Electrical Supply



Safety First!

The electrical safety of this appliance can only be guaranteed if it is correctly and efficiently earthed, in compliance with National and local regulations on electrical safety. Always ensure that the earthing is efficient. If you have any doubts, contact a qualified electrician to check the system.

The manufacturer declines all liability for damage resulting from a system which has not been earthed. On no account should it be earthed only to the water supply pipe.

The appliance must be connected to mains protected by a certified safety switch (double pole) with a capacity appropriate for the application and in compliance with National and local regulations on electrical safety.

In the UK this appliance must be connected to a 230 Volt 50Hz 13 amp fused switched socket outlet, installed to the latest edition of the IEE regulations, using a 3 pin BS approved 13 amp fused plug and in compliance with National and local regulations on electrical safety in other countries.

Important: If any internal fuses become damaged or fail in any way they must be replaced by the correct fuse available from the manufacturer quoting the information written on the label adjacent to the relevant fuse-holder.

Important: If the mains lead becomes damaged in any way it must be replaced by a lead available from the manufacturer.

2.4 Commissioning Procedure

A trained installation engineer must carry out the following procedure before your machine can be used for the first time. Ensure that the electrical and water services to the machine are connected correctly. Check for leaks in the water supply.

1. Open the front door of your machine.
2. Ensure that the waste bucket is fitted correctly. Clip the level detector and overflow pipes correctly onto the rim of the bucket.
3. **Cup Turret.** Remove the lid and fill the tubes with the correct size cups for the cup catcher type fitted to your machine. Allow the cups to drop into the tubes directly from the packaging. **DO NOT** touch the cups with your hands.



Important: Do not fill the tube directly above the cup dispense position. Allow the cup turret motor to rotate a full tube to the cup dispense position when the machine is powered up. Rotating the cup turret by hand will damage the mechanism.

Note: If you are loading paper cups, first inspect each pack for damage to the cup rims. Damaged cups must not be used.

4. Turn the machine on with the main switch on the back panel. The cup turret mechanism will index the first available cups to the dispense position and drop the cup stack into the cup drop mechanism. Fill the remaining empty cup stack with cups and replace the lid.

5. **All Models:** The water inlet valve will open and the heater tank will start to fill. As the water heats, ensure that no water overflows from the heater tank overflow pipe into the waste bucket. When the machine has powered up, the LCD will display the message as shown opposite. Check the system for leaks.



Note! The machine has a safety cut-out which will only allow the heater tank to fill for a maximum of two minutes. If after power-up the heater tank has not filled within this time, the mains power supply should be switched off and then on again to reset the heater tank time-out.

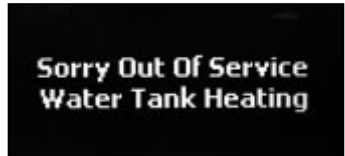

After the above message the "Sorry Out Of Service Water Tank Heating" message is displayed.

6. **B2C Models:** While the machine is powering up, the LCD will display the "Initialising" message. As the machine initialises a small amount of water is pumped through the system and is discharged into the waste bucket.
7. Before using the B2C machine for the first time it is necessary to purge the water system to ensure any water left in the system during transport is purged. When the machine enters standby press button 9 on the Service Keypad fitted inside the door. The machine will pump approximately 400ml of water through the system, discharging it into the waste bucket.
 - Ensure the Time and Date are set correctly
 - Perform Co-Ex Clean
 - Once the cleaning cycle is complete power cycle the machine.



Important: Should the machine fail to fill correctly or leak, turn off the stopcock and the power to the machine before investigating the fault.

8. Check the LCD display on the front of the machine to ensure that the water has heated to the correct temperature and that the machine is in standby mode.

A machine set to free vend mode will alternate the messages:



N.B. Messages displayed in standby mode will change depending upon the monetary device fitted and how the machine is set up during programming.

9. **All Models:** Rotate soluble/freshbrew ingredient canister outlets to upright position.

Remove each canister in turn and fill with the correct ingredient

DO NOT place the canister on the floor or overfill with ingredient.

10. **B2C Models:** Close the outlet slide to seal the fresh beans canister outlet before removing the canister from the machine.

DO NOT place the canister on the floor.

Fill the canister with fresh coffee beans. Refit the canister lid and fit the canister into the machine, ensuring that it is located correctly. Open the outlet slide to ensure correct operation.

N.B. To maintain optimum drink quality, Crane Merchandising Systems recommend that the bean canister is replenished on a daily basis.

11. Press the Cup Test button (7), located in the Service Keypad on the rear of the door and ensure that a cup is ejected cleanly from the cup drop unit.
12. Press the Park Head button (8), located in the Service Keypad on the rear of the door and ensure that the dispense head moves to its fully extended position. Press the button again to return the dispense head to its correct (homed) position.
13. Freshbrew Models: Ensure the brewer guard and brewer waste container are fitted correctly. Slide the container into position directly under the brewer.
14. B2C Models: Ensure that the brewer waste container is fitted correctly beneath the CoEx® brewer unit and tea brewer unit (if fitted).
15. Refer to the Section:5 - Programming Mode, use the menu selections available to programme the required settings for correct machine operation e.g. drink prices, disable selections, time and date etc.
16. If fitted, check that the coin mechanism and cash box operate correctly. Fill the coin tubes with correct coinage. Ensure coin return mechanism functions correctly.
17. Operate the machine through its complete range of selections to ensure that each vend is correctly dispensed.
18. Close the cabinet door. Ensure that the machine is left in a clean and safe condition.

2.5 Setting Up the Carbonator Unit (Where Fitted)

1. Open the cabinet door. Fit the seal (1), provided in the installation kit, to the regulator as shown in the photograph. Connect the regulator to the gas bottle.
2. Tighten the locknut. Carefully lift the cylinder into the machine ensuring that the gas supply pipe is not trapped or obstructed in any way.

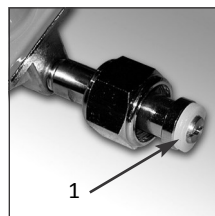

Safety First! The cylinder may be heavy. Always follow the correct procedure when lifting heavy objects.

3. Secure the gas bottle with the safety chain. Turn on the gas supply from the bottle and ensure that the regulator (2) is indicating a gas pressure of 35 PSI.
4. Place the carbonator overflow pipe into the waste bucket. Fill the carbonator water bath with clean cold water until it starts to flow from the overflow pipe.
5. Switch on the carbonator unit using the Cold Unit switch located near the power supply.
6. Place the syrup containers in the bottom right-hand side of the cabinet and insert the dip tubes into the containers ensuring that the correct flavours correspond to the drinks displayed on the selection decals.
7. Prime the syrup selections ready for use by pressing button 13 on the service keypad. The LCD will display the screen opposite.



N.B. Ensure that the waste bucket is empty and in place before priming the pumps.

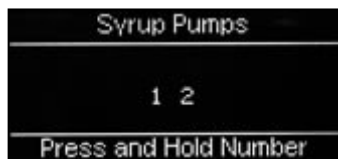

8. To prime syrup pump 1, press and hold button 1 on the drink selection keypad until the syrup appears from the dispense head. Repeat for syrup pump 2 by pressing and holding button 2 on the drink selection keypad. Press the X (Exit) key to return the machine to standby mode. Empty the waste bucket and refit to the machine.
9. Test vend the carbonated drinks to ensure correct operation of carbonator unit. Check for leaks and ensure that the machine is left in a clean and safe condition. Close the door.

N.B. If a still unit is fitted ensure that the ingredient timers for syrup drink 1 and 2 are set to 6 seconds (recommended).

2.6 Warranty Card

Please complete and return the warranty card that comes with the machine. Use the card to note any problems you encountered during installation, your feedback helps us to improve our products and services. Return the warranty card, whether problems were encountered or not, **failure to do so may invalidate your warranty.**

Section 3 - Selecting A Drink - Build A Drink

VOCE machines are available with an intuitive build a drink interface or can be used with a numeric selection menu. Both selection methods allow the user to produce a drink to their preferred taste and strength.

3.1 Selecting A Drink - Build A Drink

Drink selections are made by pressing the appropriate selection buttons on the keypad and then utilising the keypad strength selection buttons and the LCD display to alter the drink strength and to add milk/sugar to suit the customer's personal preference. When in standby mode, all available drink selection buttons will be lit indicating that the drink is able to be selected. At this time the Milk, Sugar and Start buttons are not lit.

The following example describes how to vend a Freshbrew Tea selection from a Freshbrew machine set to "Free Vend"

1. Press selection for Freshbrew Tea on the keypad. All of the other selections buttons will be extinguished, the Milk, Sugar and Start buttons will light up and the machine exits from standby mode. The LCD will display the screen as shown opposite.

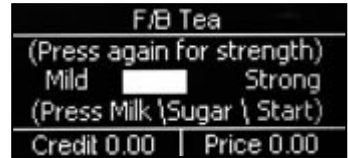

N.B. The default strength setting for this drink selection is Normal as shown.

2. To obtain a Strong or Mild beverage it is necessary to press the current drink selection button. Pressing will step through the Strong and then Mild selections.

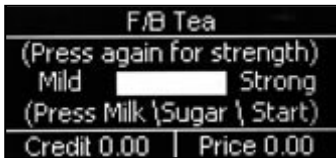

3. If the customer requires milk it is necessary to press the milk button.



4. If Extra Milk is required the customer presses the milk button a second time. A third press will enable the minimum amount of Milk selection.



5. If the customer requires sugar it is necessary to press the sugar button.



6. If Extra Sugar is required the customer presses the sugar button a second time. A third press will enable the minimum amount of Sugar selection.

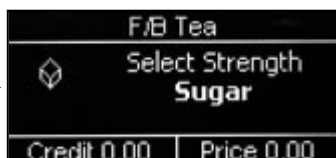

7. Once the required drink has been selected, press the Start button on the keypad. All lit buttons will be extinguished apart from the drink selection button which flashes indicating that the drink is being vended.

Unless the customer has placed their own cup into the dispense area, a cup will automatically be ejected from the cup drop unit into the dispense area and the drink selection will be delivered into the cup. Whilst this operation is in progress the LCD will display the screen shown opposite.



8. After the beverage has been dispensed the LCD will display the message Thank You and the machine will beep once. The message on the display will change to read Please remove cup. The drink can then be carefully removed from the dispense area and the machine will return to standby mode.

9. Certain drink selections do not allow the strength option to be selected or milk added. For example, if the customer presses the Cappuccino selection button, all of the other selection buttons will be extinguished, the Sugar and START buttons will light up and the LCD will display the screen opposite.

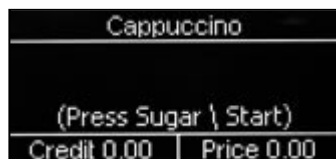

The customer can either press the START button to vend the drink or first press the sugar button in order to add sugar to their taste as described previously.

10. Other drink choices do not allow the strength option or milk/sugar to be selected. For example, if the customer presses the Chocolate selection button, all of the other selection buttons will be extinguished, the START buttons will light up and the LCD will display the screen opposite.

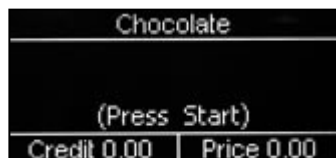

The customer simply presses the START button and the machine will vend the drink as described above.

3.2 Selecting A Drink - Cold Drink Selections

VOCE machines may be fitted with either a chiller or carbonator unit allowing cold water and flavoured drinks to be vended, either still or both still and sparkling.

The following example describes how to vend a cold flavoured drink from a VOCE machine fitted with a carbonator unit.

1. Press the selection button for the cold flavoured drink required on the keypad. All of the other drink selection buttons will be extinguished, the START button will light up and the machine exits from standby mode. The LCD will display the screen as shown opposite.



N.B. The default setting for cold drink selections is still.

2. To obtain a Sparkling drink press the current drink selection button. Pressing the button again will revert back to the Still setting.
3. Once the drink has been selected, press the START button on the keypad. The drink selection button will flash indicating that the drink is being vended. Unless the customer has placed their own cup into the dispense area, a cup will automatically be ejected from the cup drop unit into the dispense area and the drink selection will be delivered into the cup. Whilst this operation is in progress the LCD will display the "Serving" screen.
4. After the cold drink has been dispensed the LCD will display the message Thank You and the machine will beep once. The message on the display will change to read Please remove cup. The drink can then be removed from the dispense area and the machine will return to standby mode.

3.3 Selecting A Drink – Keyless Jug/Free Vend Transition

These features enable the user to obtain a free and a jug vend. Both these features are password protected and are available using the numbered keys on the drink selection keypad. Follow the instructions below:

Free Vend

1. Press the 'Start' and '3' keys together.
2. Enter your password in the displayed screen, using the numbered keys.
3. Press the 'Edit/Sugar' key to enter the Free Vend mode and select the required drink.

Jug Vend

1. Press the 'Start' and '2' keys together.
2. Enter your password in the displayed screen, using the numbered keys.
3. Press the 'Edit/Sugar' key to enter the Jug Vend mode.
4. Place the jug in the dispense area and select the required drink.

The machine reverts to 'normal' mode if there is no activity for 30 seconds, or it can be placed back to 'Normal' mode:

1. Press the 'Start' and '4' keys together.

3.3.1 Set-Up

To enable these two features and create the passwords, access to the Engineer Program Main Menu is required. Follow the instructions below:

1. Enter the Engineers Program 'Main Menu', scroll down and select 'System Settings'.
2. Select 'Key-Less Transitions', select 'either On' or 'Off'.
3. Press 'Edit/Sugar' and then 'Exit/Milk' key.
4. Scroll down to and select 'Security Codes'.
5. Scroll down to 'Enter Free Vend Pin' and press 'Edit/Sugar'
6. On the screen displayed enter a pin number and press 'Edit/Sugar'.
7. Scroll down to 'Enter Jug Vend Pin' and press 'Edit/Sugar'
8. On the screen displayed enter a pin number and press 'Edit/Sugar'.
9. Press 'Exit/Milk' to exit the menu.

Important note: If you intend to use this feature you MUST change the password to one of your own choosing.

3.4 Replacing/Updating Drink Selection Decals

Self-adhesive drink selection and pricing decals are mounted onto a decal carriers located behind the main panel. To update drink pricing or replace drink description decals, proceed as follows:

1. Open the front door of the machine.
2. Carefully remove the decal carrier from the machine. Place the decal carrier face-up on a clean, flat surface.
3. Updating drink pricing: Carefully remove the previous price decals from the drink selection decals. Update the prices where necessary using new self-adhesive decals. These are available as spares from the manufacturer.
4. Updating drink selections and pricing: When updating selection decals and prices it may be necessary to use a new decal carrier. These are available as spares from the manufacturer.
5. Peel the relevant drink selection decals from their backing sheet and apply to the decal carrier using the printed guides.

Important: Ensure that drink selections used relate to drink choices programmed into the machine software.

6. Apply price decals as described above.
7. Place the decal carrier ensuring that the drink selections are visible through the pre-cut viewing area.
8. Close the front door and ensure that the machine returns to standby mode.



Section 4 - Service Keypad Functions

VOCE machines are fitted with a service keypad mounted on the rear of the door. This keypad contains the Program entry key and also allows the operator to carry out specific functions during routine cleaning and maintenance.

N.B. During certain operations e.g. View Counters it is necessary for the operator to utilise the selection keypad and LCD mounted on the front of the door to access data. Please refer to Section 6 - Programming Mode for details of selection keypad layouts and functions.

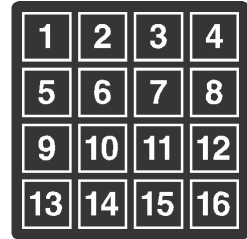

4.1 Button 1 - Program Entry

This button enables the operator to access the Engineer Program (refer to Section 6).

4.2 Button 2 - Brewer Open (Oltre Brewer)

The brewer should return to its fully open position at the end of the vend cycle. In the unlikely event that the brewer chamber is closed Press '2' on the service keypad, the brewer will start to move & will stop at the open position.

4.3 Button 3 - Rinse/Flush

The flush sequence rinses the mixing bowls. Before the sequence begins, the system waits until the water in the boiler is at the set temperature. In order to guarantee the highest standards of cleanliness, the boiler fill valve is disabled, ensuring that the water used in the sequence is delivered at the optimum temperature to kill any micro-organisms. Each hot water valve and the corresponding whipper are switched on in sequence. Once the flush cycle is complete the machine returns to standby mode.

To flush the machine:

1. Press and release the Flush button (3). The flush sequence begins.
2. Empty the waste water container when complete.



Caution: Ensure that a suitable container is placed under the dispense position. Keep hands away from the dispense area whilst the flushing cycle is in operation.

4.4 Button 4 - Brewer Clean (Oltre Brewers only)

1. The brewer clean button rinses the Oltre brewer/s.
2. During the cleaning cycle the LCD shows the message shown.
3. Once the cleaning cycle is complete, the boiler refills and when the water is at the required temperature the machine returns to standby mode ready to vend.

**Sorry Out Of Service
Rinsing**

4.5 Button **5** - View Counters

The View Counters button (5) enables the operator to access the Data Recall Menu. Entry into this menu allows the operator to view Non-Resettable and Resettable Sales Data, view data relating to Timed Events and Identification Numbers of installed components and (if the feature is enabled) view SureVend™ assisted vend data. The Resettable Sales Data and SureVend™ Data menus contain an extra sub-menu which allows the operator to delete the current data from the machines memory. Refer to Section 6.1 Data Recall Menu for full details relating to this menu and its contents.

4.6 Button **6** - Test Vend

The Test Vend button (6) enables the operator to vend a drink from the machine to ensure correct operation after cleaning or maintenance.

1. When the button is pressed and released the LCD will display the screen as shown opposite. Press a drink selection button followed by the **START/?** button to begin the vend sequence.
2. Ensure that the selection is correct, has not under/overfilled the cup and most importantly, tastes good!
3. Press the **X** (Exit) key on the drink selection keypad to exit from the Test menu and return to stand-by mode.

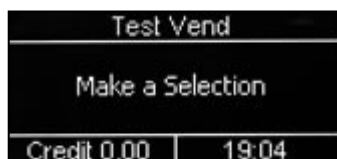

4.7 Button **7** - Cup Test

This button enables the operator to test the operation of the cup drop unit after refilling the cup stacks. When the button is pressed the cup drop motor is operated and a cup is ejected from the cup drop unit. This function ensures that the mechanism is working correctly.

4.8 Button **8** - Park Head

When this button is pressed, the dispense head moves to its fully extended position and stops. Press the button again to return the dispense head to its correct (homed) position.

4.9 Button **9** - Boiler Fill (B2C Machines)

When this button is pressed, the machine pumps a measured amount of water through the system - approximately 400ml, heating it as it does so. This ensures that heated water is immediately available when a drink is selected. This button should also be used to purge any water left in the system after the machine has been moved or shut down for any length of time.

4.10 Button **10** - Machine Cool Down (B2C Machines)

This button enables an engineer to work safely on the B2C module.

When this button is pressed the hot water in the pressure system 370ml of cold water is passed through the system to remove the hot water which is there at standby. When complete the Message "Machine Cooled" is displayed and all outputs disabled, at this stage once the power to the machine has been disconnected the engineer can work safely on the B2C module (refer to Section 9.3 for full details).

4.11 Button **11** - CoEx® Tablet Clean (B2C Machines)

This button when pressed, initiates the CoEx® brewer tablet cleaning routine. Crane Merchandising Systems recommends that this brewer cleaning routine should be carried out on a weekly basis (refer to the Operator's Manual for full details).

4.12 Button **12** - Reset Waste Counter (F/Brew & B2C Machines)

This is only relevant if the feature is turned on during installation.

Every time that the waste container is emptied the waste counter must be reset. Press button 12 on the service keypad. Two audible bleeps confirm that the counter has been reset to zero.

4.13 Button **13** - Syrup Prime (Still/Carbonated Machines)

This button enables the operator to prime the syrup selections after replacing a syrup container. Refer to Section 2.5 for full details of this operation.

4.14 Button **14** - Clear SureVend™ Error

This button enables the operator to simply and quickly clear SureVend™ errors caused by cup drop failures.

4.15 Button **15** - Start

This button has the same functions as the **START** key on the drink selection keypad.

Section 5 - Programming Mode

5.1 Drink Selection Keypad

Programming mode utilises the drink selection keypad and allows the operator to view and alter stored data within the machines memory. VOCE machines are fitted with a build a drink style and numeric selection interface.

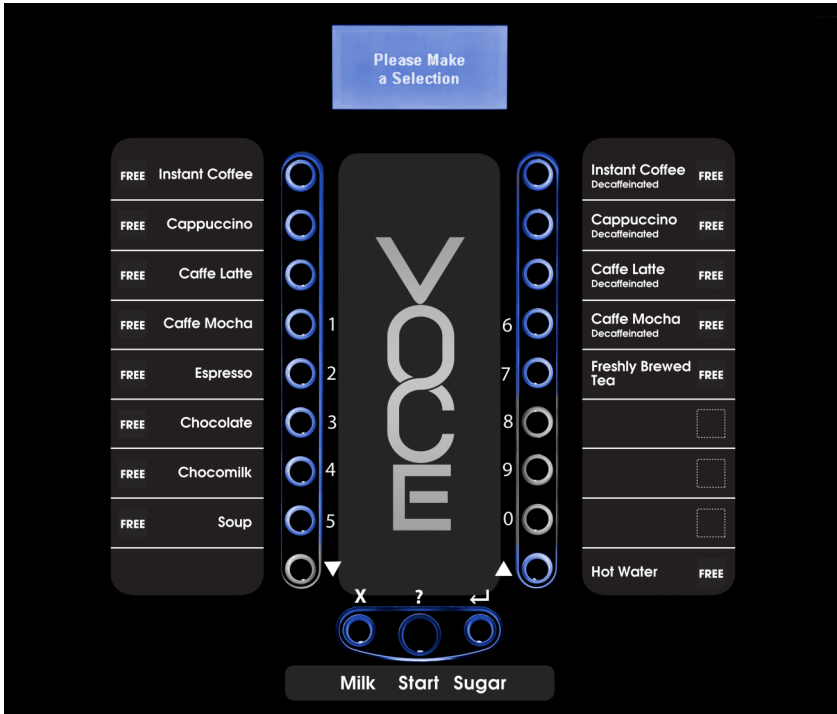

During programming the keys are used as follows:

- Keys 0-9 Used for entering text and numerical data
- ▲ For indexing up in a program, or incrementing data
- ▼ For indexing down in a program, or incrementing data
- ↵ Edit key. Used to select and enter the highlighted menu and to save data to machines memory
- X Exit key. Press to return to the previous menu screen
- START/?** Press to "set all" or "clear all" data or begin a test sequence.

5.2 Menu Display

The VOCE range of freestanding drinks vending machines feature Crane Merchandising Systems interactive menu display. The multi line LCD display helps to make navigating the programming menu structure easy and intuitive. It is used to display programming information and will change according to the type of data being updated.

1. The top line of the screen is the Menu title.
2. Selected items are highlighted in white. Press the ▲(up) or ▼(down) keys on the drink selection keypad to highlight an item.
3. Press the ↵ (Edit) key to select the item. In this example, pressing the ↵ (Edit) key will display the Mug Discount screen.
4. The bottom line of the screen will often show important information. In certain configuration menus it will display the current value for the selected item. This is a useful way to quickly check stored settings and also confirm that a value has been altered correctly.
5. To return to the Main Menu from any screen, simply press the X (Exit) key until you reach the Main Menu.



5.3 Accessing the Programming Mode

1. Open the front door of the machine.
2. Press the Program Entry key (1) on the service keypad, located inside the door. The LCD will display the screen as shown opposite. Enter the 4 digit engineer entry pin code.
3. Press the ↵ (Edit) key. Providing the operator has entered the code correctly, the LCD will display the screen as shown opposite. Press the ↵ (Edit) key to access the Engineer Program or X (Exit) key to return the machine to standby mode.
4. The LCD on the front of the machine will display the top level programming menu screen - Main Menu. The first available menu Data Recall is highlighted indicating that it can be selected. To move to a different menu press the ▲(up) or ▼(down) keys on the drink selection keypad until the required menu is highlighted.

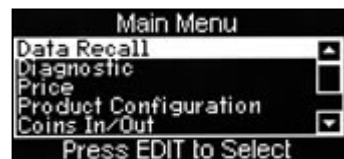

N.B. Coins In/Out will only be displayed on machines fitted with an MDB coin mech.

- With the required menu highlighted, press the ↵ (Edit) key to select it. Using the Price menu as an example, the LCD will display the sub menus as shown opposite.



- Using the ▲(up) or ▼(down) keys, the ↵ (Edit) key and the X (Exit) key it is possible to easily navigate through all of the menus contained within the Engineer Program.
- To update parameters, key in the actual digits of the number required using the selection keys 0-9. Once the correct parameter has been entered, press the ↵ (Edit) key to overwrite the previous value and save the new parameter in the machines memory. Pressing the X (Exit) key will move back to the previous screen.

Certain programming functions require that the engineer chooses either one or multiple parameters within a sub program. These can take the form of either check boxes or radio buttons.

- Check Boxes:** The example opposite shows the Days of Week screen accessed via the Sanitation Events Menu which allows the engineer to choose multiple days of the week on which a specific function will take place.

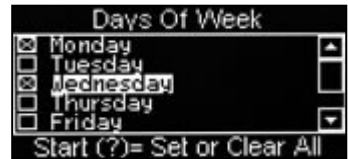

- Using the ▲(up) or ▼(down) keys, scroll through until the required day is highlighted as shown. Pressing the ↵ (Edit) key will select the day, indicated by an X appearing in its adjacent box.

Continue until all required days have been selected. Pressing the X (Exit) key will move back to the previous screen and save the new settings to the machines memory.

N.B. Pressing the **START/?** key on the drink selection keypad will check all boxes if empty or clear all boxes if checked.

- Radio Buttons:** The example opposite shows the State screen accessed via the Timed Events Menu which requires the engineer to select one of the options shown. Use the ▲(up) or ▼ (down) keys to set the required option followed by the ↵ (Edit) key to store/save it (indicated by the filled radio button).



All engineer programming for the VOCE range follows the procedures as described above. Specific program actions are described fully in the following section.

5.4 View Diagnostics

Using the Drink Selection keypad, and without opening the machine door, it is possible to quickly view the Diagnostic screen and any faults that may have occurred within the machine.

1. Press and hold the **X** (Exit) key and then press 1 on the main keypad to display the Diagnostic Menu.
2. Press the ↵ (Edit) key to enter the menu. Use the ▼ (down) key to scroll down any faults listed and press the ↵ (Edit) key to view details of the fault.
3. Use the **X** (Exit) key to exit the menu.



Section 6 - Engineer Program

To access the Engineer Program, enter the programming mode as described in section 6. Once in the Engineers Program the LCD on the front of the machine will display the top level programming menu screen - Main Menu.

N.B. Coins In/Out will only be displayed on machines fitted with an MDB coin mech.

Using the ▲(up) or ▼(down) keys, ↵ (Edit) key and X (Exit) key on the drink selection keypad the engineer can navigate quickly and easily through the Engineer Program menus as described in Section 6.

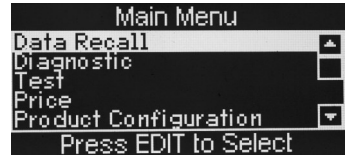

Free Vend
 Coins In/Out
 System Settings
 Security Codes
 Timed Events

6.1 Data Recall Menu

Entry into this menu allows the engineer to view Non-Resetable and Resetable Sales Data, view data relating to Events and Identification Numbers of installed components and (if feature enabled) view SureVend™ assisted vend information. The Re-settable Sales Data and SureVend™ data menus contain an extra sub-menu which allows the engineer to delete the current data from the machines memory.



6.1.1 Non Resetable Sales Data

This menu allows the engineer to view and record monetary and sales values. This data cannot be reset and will remain intact for the service life of the controller board (unless the back-up battery is removed).

1. From the Data Recall screen highlight Non Resetable Sales Data and press the ↵ (Edit) key. The LCD will display the screen as shown opposite. From this menu the engineer can view data for the Overall Totals (highlighted), By Product, along with data relating to Cash, Cashless and Token Vends.

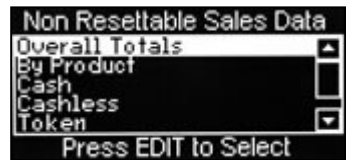

2. To view the Overall Totals screen, press the ↵ (Edit) key on the drink selection keypad.

This menu displays both the total £ amount and total vend counts for the following data:

All Data-£	Displays the total machine sales in £
All Data-#	Displays the total number of machine vends
Sales-£	Displays the total machine sales in £ except free and test vends
Sales-#	Displays the total number of machine vends. Including normal, discount and surcharge vend totals but not free and test vends
Discount-£	Displays the total monetary value of all discounts in £
Discount-#	Displays the total number of discounted vends
Test Vend-£	Displays the total monetary value of all test vends in £
Test Vend-#	Displays the total number of test vends
Surcharge-£	Displays the total monetary value of all surcharges in £
Surcharge-#	Displays the total number of surcharge vends
Free Vend-£	Displays the total monetary value of all free vends in £
Free Vend-#	Displays the total number of free vends

N.B. All sales data is presented in a format required by the latest European Vending Association Data Transfer Standards (EVA DTS). Surcharge data fields are not supported by VOCE machines.

3. Scroll through the list displayed using the ▲(up) or ▼(down) keys on the front panel and record the audit data.

When complete, press the X (Exit) key on the drink selection keypad to return to the Non Resettable Sales Data menu screen.

Overall Totals	
All Data-£	0.00
All Data-#	1
Sales-£	0.00
Sales-#	0
Discounts-£	0.00
Discounts-#	0

4. The engineer can also view data by individual product. Press the ▼(down) key on the drink selection keypad to highlight By Product on the Non Resettable Sales Data menu screen.

Overall Totals	
Test Vend-£	0.00
Test Vend-#	0
Surcharge-£	0.00
Surcharge-#	0
Free Vend-£	0.00
Free Vend-#	1

5. Press the ↵ (Edit) key on the keypad to enter the By Product menu screen. This menu contains all of the drink selections available from the machine. Use the ▲(up) or ▼(down) keys on the drink selection keypad to scroll through the menu until the required selection is highlighted.

- Press the ↵ (Edit) key on the keypad to enter the highlighted selection e.g. Instant Coffee. The LCD will display the screen as shown opposite.

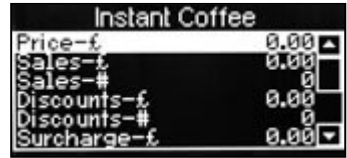

The engineer can then scroll through the list displayed using the ▲(up) or ▼(down) keys on the drink selection keypad and view the audit data.

Surcharge - #
 Test Vend - £
 Test Vend - #
 Free Vend - £
 Free Vend - #

N.B. Individual By Product screens also display the price set for the selection as shown

- When complete, press the X (Exit) key on the drink selection keypad to return the machine to the previous screen. The engineer can then view data for more selections using the procedure described above and also access further menus via the Non Resettable Sales Data menu relating to Cash, Cashless and Token audit data.
- To return the machine to standby mode, press the X (Exit) key repeatedly until the LCD displays the standby screen.

6.1.2 Resettable Sales Data

This menu contains similar data to that available from the Non Resettable Sales Data menu. However, once viewed data from this menu can be cleared from the machines memory.

- From the Data Recall screen, highlight Resettable Sales Data and press the ↵ (Edit) key. The LCD will display the screen as shown opposite and allow the engineer to view data for all parameters as described for Non-Resettable Sales Data.

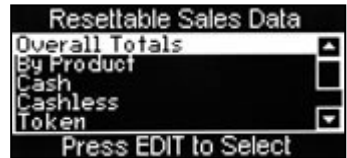

Additionally the menu allows the engineer to delete all resettable data via the Clear Data menu.

- To view the Overall Totals screen, press the ↵ (Edit) key on the drink selection keypad. This menu displays both the total £ amount and total vend count (since the last time it was cleared) for the data fields shown.



N.B. Refer to Section 6.1 Data Recall Menu for detailed descriptions of these data fields.

- Scroll through the list displayed using the ▲(up) or ▼(down) keys on the front panel to view the audit data. When complete, press the X (Exit) key on the drink selection keypad to return to the Resettable Sales Data menu screen.



- The engineer can also view the resettable monetary and vend data for individual product by entering the By Product menu, and also view data relating to Cash, Cashless and Token vends using their relevant sub-menus.

Once the engineer has viewed the required information from these sub-menus, the data can be deleted via the Clear Data sub menu.

- From the Resettable Sales Data screen, highlight the Clear Data sub menu using the ▼ (down) key and press the ↵ (Edit) key.

The LCD on the front of the machine will display the screen as shown opposite, warning the engineer that all data will be deleted.

Either press the ↵ (Edit) key to clear the data or press the X (Exit) key to exit the menu without clearing the data.



6.1.3 Events

- From the Data Recall menu scroll down and highlight Events then press the ↵ (Edit) key. The LCD will display the screen as shown opposite. From this menu screen the engineer can access and view information relating to the four events as shown.



- To view the Power Losses screen, press the ↵ (Edit) key. The screen displays a list of the 10 most recent occasions when power to the machine has been interrupted in date, time of day and period format. Press the X (Exit) key to return to the Events menu.

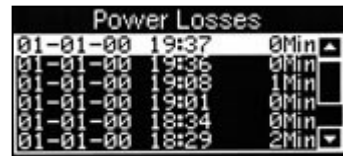

- Press the ▼ (down) key to highlight Last Data Clear, Last Vend and Last Clock Set. Information for these events is displayed along the bottom of the screen.

6.1.4 Identification Numbers

From the Data Recall menu scroll down and highlight Identification Numbers then press the ↵ (Edit) key. The LCD will display the screen as shown opposite. From this menu the engineer can access and then view serial number, part number and version type information relating to the main PCB and any MDB coin/card mechanism fitted to the machine.

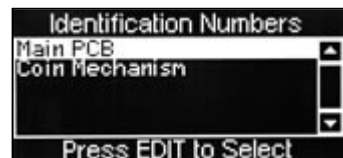

N.B. Coin Mechanism, Bill Validator and Card Reader will only be displayed if an MDB device is fitted to the machine.

6.1.5 SureVend™

This menu becomes available when SureVend™ is enabled via the Product Configuration menu (refer to section 6.5.4 SureVend™).

1. From the Data Recall menu scroll down and highlight SureVend™ then press the ↵ (Edit) key. The LCD will display the screen as shown opposite. From this menu screen the engineer can view and record the number of cup drop failures that SureVend™ has logged and also the number of SureVend™ assisted vends.
2. Once the engineer has viewed the data it can be cleared via the Clear Data menu as described previously.

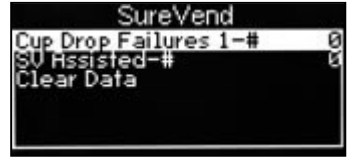

6.1.6 Mug Vends

This menu displays the number of vends that the machine has made without dropping a cup. The data can be cleared via the Clear Data menu as described previously.

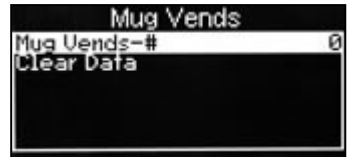

6.1.7 Cup Vends

This menu displays the number of cup drop vends that the machine has made. The data can be cleared via the Clear Data menu as described previously.

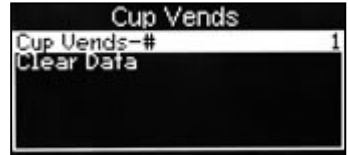

6.1.8 Print Data

This menu displays the data that can be extracted from the machine when a printer is connected and the corresponding keypad number which needs to be pressed to send the data to the printer.



6.2 Diagnostic Menu

Should a fault occur within the machine, the LCD will display a fault message and in some cases the machine may become inoperable. By accessing the Diagnostic menu and viewing the fault description the engineer can in most cases clear the fault and quickly bring the machine back into service.

When the fault cannot be remedied by the engineer and requires the services of an approved engineer, the diagnostics screen text displayed enables the engineer to quickly and easily locate and repair the problem, reducing machine down time.

6.3 Test

This menu allows the Engineer to test most of the components in the machine and also view various switch and sensor inputs to ensure correct operation. On entry to the Test menu The LCD will display the screen as shown.

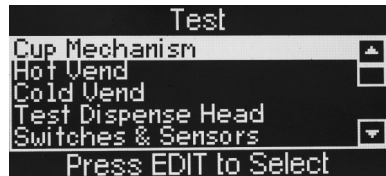

Test Vend Without Cups
 Test Vend
 Grinder Test
 Door Lighting
 Display
 Keypad Test

6.3.1 Cup Mechanism

This menu allows the engineer to test the operation of the cup drop unit.

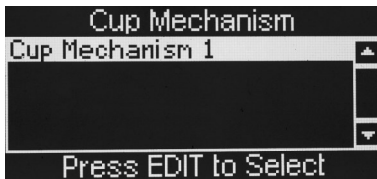

6.3.2 Hot Vend

This menu allows the engineer to test the operation of the ingredient motors, whipper motors and main heater tank valves.

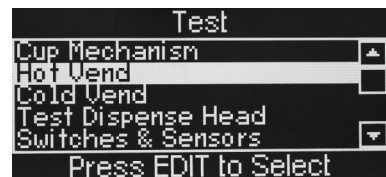

6.3.2.1 Auger

This menu allows the engineer to select and run the individual ingredient motors (once selected a motor will run for three seconds).

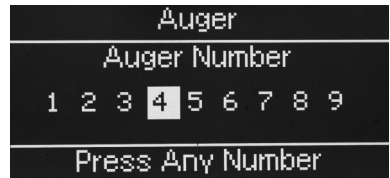
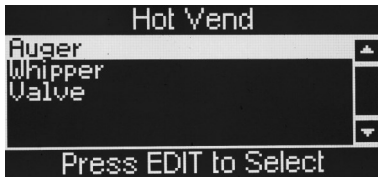

6.3.2.2 Whipper

This menu allows the engineer to select and run the individual whipper motors (once selected a motor will run for three seconds).

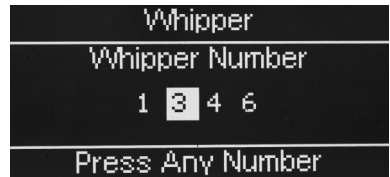
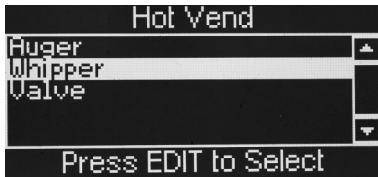

6.3.2.3 Valve

This menu allows the engineer to select and run the individual hot water dispense valves on the main heater tank (once selected a valve will open for four seconds).

N.B. This feature should be used to set up valves when they are repaired or replaced. As all flow rates should be set to 20ml per second each actuation of a valve should dispense 80ml with the restrictor screw on the valve being adjusted to achieve this.

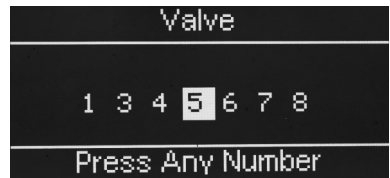
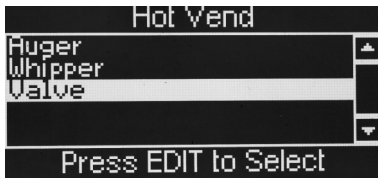

Important: Do NOT use this feature to test the valves feeding any Oltre brewers as they will not be in the sealed position and hot water will not be directed into the waste bucket.

6.3.3 Cold Vend

This menu allows the engineer to test the operation of the syrup pumps and the cold water and carbonated water dispense valves.

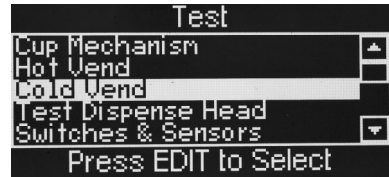

6.3.3.1 Syrup Pumps

This menu allows the engineer to select and run the individual syrup pumps.

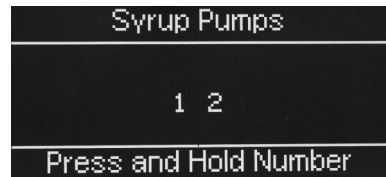
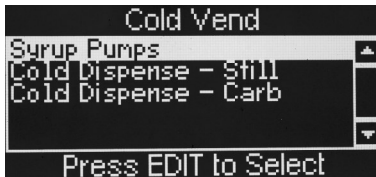

6.3.3.2 Cold Dispense - Still

This menu allows the engineer to select and run the cold still water dispense valve (once selected the valve will open for four seconds).

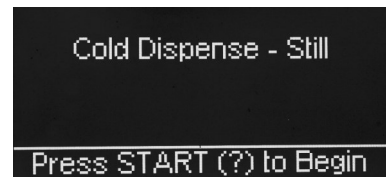
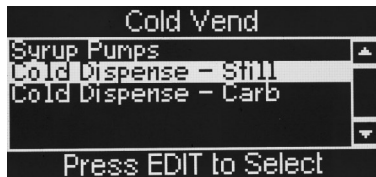

6.3.3.3 Cold Dispense - Carbonated

This menu allows the engineer to select and run the cold carbonated water dispense valve (once selected the valve will open for four seconds).

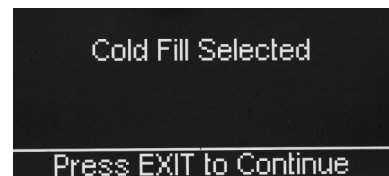
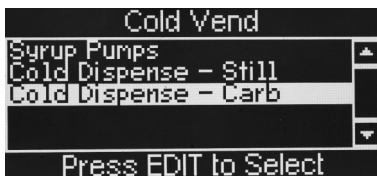

6.3.4 Test Dispense Head

This menu allows the engineer to test the dispense head motor, opto sensor and home switch.

The correct operation is to move forward (Moving) three times before reversing direction (Initialising) and stop when the home switch is seen (Idle).

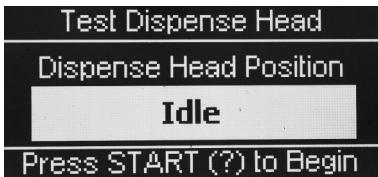
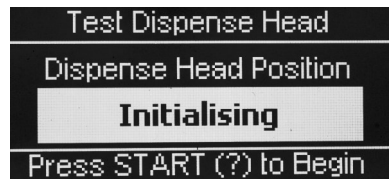
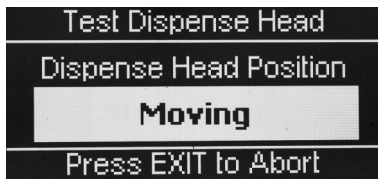
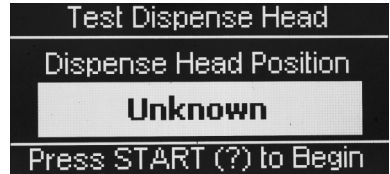
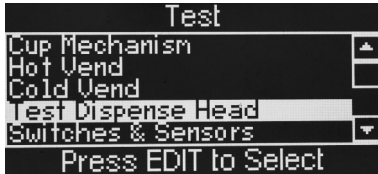

6.3.5 Switches & Sensors

This menu allows the engineer to view and test the operation of the switches and sensors within the machine.

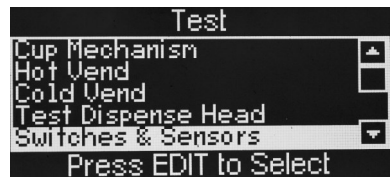

6.3.5.1 Waste Tray Sensor

This indicates the status of the waste bucket.



6.3.5.2 Cup Turret Switch

This indicates the status of the index switch on the CDU, Open indicates that the cup sleeve is aligned with the throat.



6.3.5.3 Cup Turret Sensor

This indicates the status of the sensor within the cup throat.



6.3.5.4 Cup Dispense Switch

This indicates the status of the home switch on the cup splitter motor. Open indicates that it is in the home/start position.



6.3.5.5 Mug Sensor - Current

This indicates the status of the Mug Sensor (SureVend™ sensor) 0 indicates beam not obstructed, 1 indicates the beam is broken.

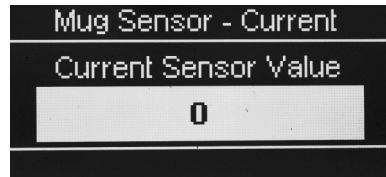

6.3.5.6 Heater Tank Level

This indicates the water level in the Main Heater Tank.



6.3.5.7 Tank Temp & Heater

This indicates the current temperature in the Main Heater Tank and also if the signal to turn the solid state relay is turned **On** or **Off**.



6.3.5.8 Brewer Switch 1-2

This indicates the status of the brewer switch and therefore the position of the brewer.

Note: At standby i.e. in the open position an Oltre Brewer the switch should **At Home**.

At standby a CoEx brewer the switch should be **Off Home**. The brewers are numbered from left to right.



6.3.5.9 Cold Fill

This indicates when the carbonator is **Full**.



6.3.6 Test Vend Without Cups

This allows drinks to be taken without the machine dropping cups.

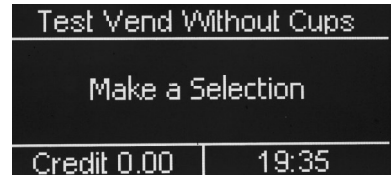
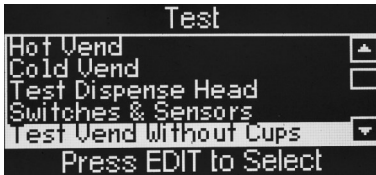

6.3.7 Test Vend

This allows drinks to be taken.

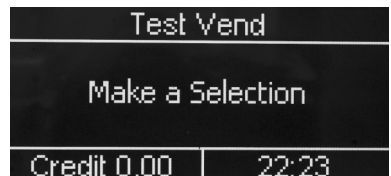
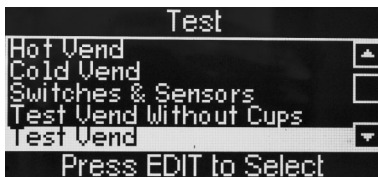

6.3.8 Grinder Test

This initiates a test run of the Grinder to check its operation.

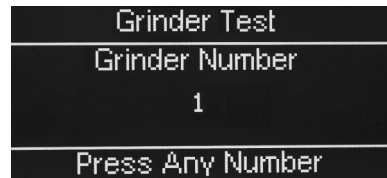
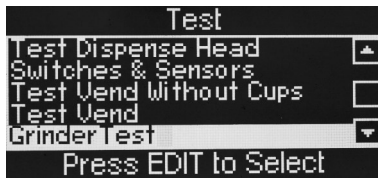

6.3.9 Door Lighting

This allows the Selection and Reject button lights to be tested.

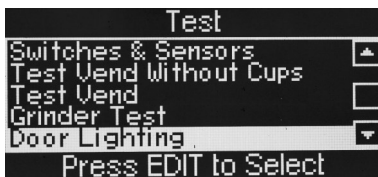

6.3.10 Display

This allows the LCD to be tested, pressing the ← (Edit) key will illuminate the various test screens.

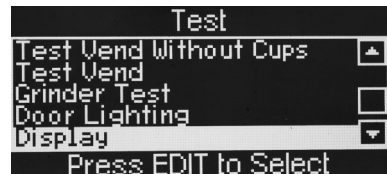

6.3.11 Keypad Test

This allows the selection and service keypads to be tested.

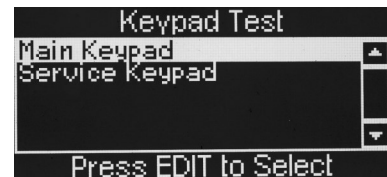
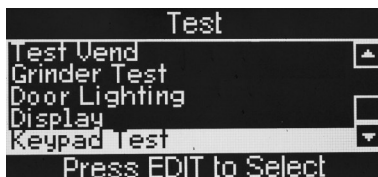

6.4 Price Menu

Entry into this menu allows the engineer to enter individual prices for each drink selection available, one price for all drink selections and set a discount to be applied for customers who use their own cup/mug. The menu also contains a sub menu which allows the engineer to view the highest and lowest price set in the machines memory.

N.B. Values entered via this menu are only applicable to machines fitted with a monetary system.

6.4.1 Individual Prices

This sub menu allows the engineer to set an individual price for each drink selection available from the machine.

1. With Individual Prices highlighted as shown opposite, press the ↵ (Edit) key to access the menu.

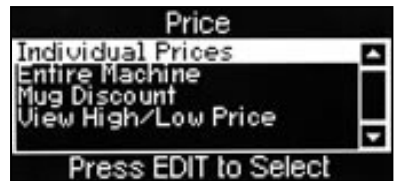

2. Upon entry into this sub menu, all drink selections available from the machine are listed along with the current drink price for the highlighted selection. The example shown illustrates an Instant Coffee selection with a price set currently at **35p**.

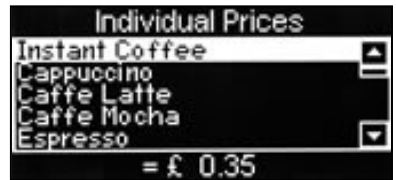

3. To change the price of the highlighted selection, press the ↵ (Edit) key. The LCD will change and display the screen as shown.



4. To update the price, e.g. increase to **45p**, press the sequence 0-0-0-4-5 using the appropriate number keys on the drink selection keypad.

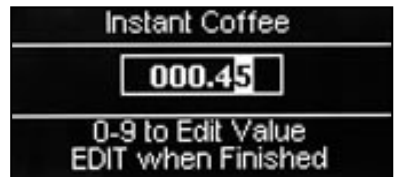

5. Press the ↵ (Edit) key to return to the Individual Prices screen and verify that the new price displays in the status line along the bottom of the display. Use the ▲ (up) or ▼ (down) keys to highlight further selections.

6.4.2 Entire Machine

This sub menu allows the engineer to set a single price for all selections available from the machine.

1. When highlighted from within the Price menu, the LCD will display the screen, with the current value (e.g. **40p**), as shown.



2. Press the ← (Edit) key to access the Entire Machine sub menu. To update the value, e.g. set a price of **50p**, press the sequence 0-0-0-5-0 using the appropriate number keys on the drink selection keypad.



3. Press the ← (Edit) key to return to the Price menu screen and verify that the new price displays in the status line along the bottom of the display.

Tip: If most selections are to be sold at the same price, use this menu to quickly set the entire machine to this price and then access the Individual Prices menu to adjust prices for individual selections. Entering a single price for the entire machine will override any individual prices previously programmed.

6.4.3 Mug Discount

This sub menu allows the engineer to program a discount value against all drink selections for customers who use their own cup/mug.

When a customer places their own cup into the dispense area and selects a drink, the SureVend™ sensors will detect the cup and disable the cup drop mechanism. The price set for Mug Discount is then subtracted from the price of the drink selected and the appropriate change/credit returned to the customer.

N.B. It is important to ensure that any value entered for a mug discount is supported by the coin mechanism fitted to the machine, e.g. if a mug discount is set at 2p but the lowest coin available from the coin mechanism is 5p, the machine will not return the discount to the customer.

1. Highlight the Mug Discount sub menu from within the Price menu. The LCD will display the screen, with a current value in the status line (e.g. **5p**), as shown. Press the ← (Edit) key to access the Mug Discount sub menu.



- To enter a discount value, e.g. **6p**, press the sequence 0-0-0-0-6 using the appropriate number keys on the drink selection keypad.



- The LCD will change and display the screen as shown. Press the ↵ (Edit) key to return to the Price menu screen and verify that the new price displays in the status line along the bottom of the display.

6.4.4 View High/Low Price

This sub menu allows the engineer to view the highest and lowest values in force, programmed via the Individual Prices sub menu.

N.B. If a single price is currently in force, this value will be displayed in both fields.

6.5 Product Configuration Menu

Entry into this menu allows the engineer to disable drink selections and turn SureVend™ On or Off. Upon entry into the Product Configuration menu the LCD will display the screen as shown.

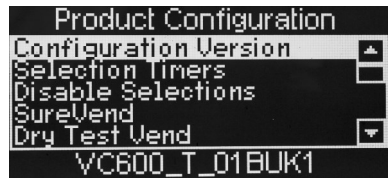

- Water Only No Cup
- Cup Size Selection
- Cup Mechanism
- CupMech Cup Capacity
- Water Module
- Low Water Reset
- Water Compensation
- Heater Tank Set-Up 1
- Heater Tank Set-Up 2
- Brewer SetUp
- Syrup Cleaning
- Brewer Waste Management
- Water Filter Management

6.5.1 Configuration Version

This displays the manufacturer configuration code for the machine and is for information purposes only.

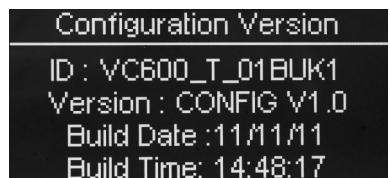
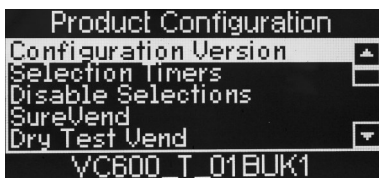

6.5.2 Selection Timers

This menu allow the recipes to adjusted to suit individual preferences.

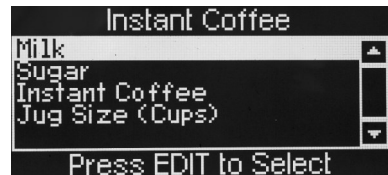
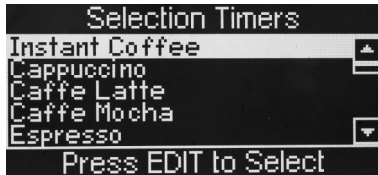
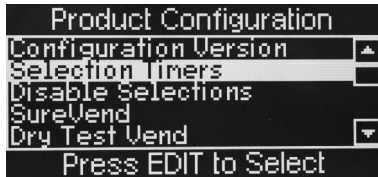

The way these drinks are set up depends on whether the machine is being used in Numeric or Build a Drink configuration.

Note: Example screens are from an Instant Coffee Numeric Machine.

This is the length of time in seconds that the valve will remain open and can be changed by entering a new value and saving the new setting by pressing the Edit button.

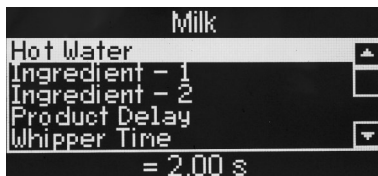

This is the length of time in seconds that the milk motor will run and can be changed by entering a new value and saving the new setting by pressing the Edit button.

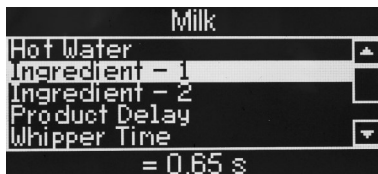

Post Dispense delay is the time the head remains in the extended position and should be set for the last ingredient to be vended.

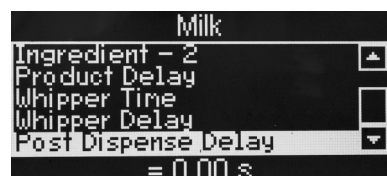

N.B. Ingredient - 1 is the normal throw of milk; Ingredient - 2 is the extra throw of milk.

N.B. When the screen is showing the ingredient run time for any of the dry ingredients pressing button 15 on the service keypad will run the appropriate ingredient motor for the displayed time.

The sugar throw is set in exactly the same way.

- N.B.** Ingredient - 1 is the normal throw of coffee
- Ingredient - 2 is the extra throw of coffee
- Ingredient - 3 is the minimum throw of coffee.

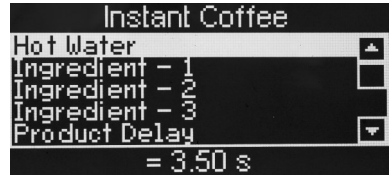

Note: Example screens are from an Instant Coffee Build a Drink Machine.

This is the length of time in seconds that the valve will remain open and can be changed by entering a new value and saving the new setting by pressing the Edit button.

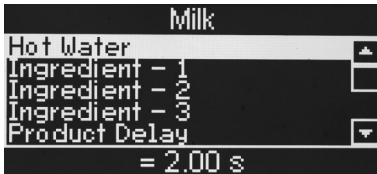

This is the length of time in seconds that the milk motor will run and can be changed by entering a new value and saving the new setting by pressing the Edit button.

- N.B.** Ingredient - 1 is the minimum throw of milk
- Ingredient - 2 is the normal throw of milk
- Ingredient - 3 is the maximum throw of milk.

N.B. When the screen is showing the ingredient run time for any of the dry ingredients pressing button 15 on the service keypad will run the appropriate ingredient motor for the displayed time.

The sugar throw is set in exactly the same way.

- N.B.** Ingredient - 1 is the minimum throw of coffee
- Ingredient - 3 is the normal throw of coffee
- Ingredient - 5 is the maximum throw of coffee.

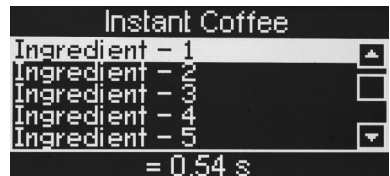

6.5.3 Disable Selections

This sub menu allows the engineer to disable individual or all drink selections if necessary. With Disable Selections highlighted; press the ↵ (Edit) key to access the menu.

Upon entry into the menu the LCD will display the screen as shown. Using the ▲ (up) or ▼ (down) keys, scroll through the menu until the required drink selection is highlighted. Pressing the ↵ (Edit) key will select the drink, indicated by an X appearing in its adjacent box.

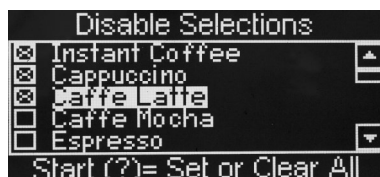
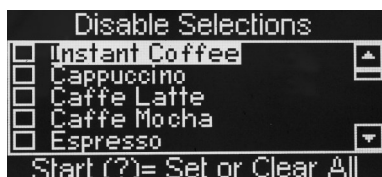

1. If necessary continue until all required drink selections have been checked. Pressing the X (Exit) key will move back to the Product Configuration screen and save the new parameters to the machines memory.
N.B. Pressing the **START/?** key on the drink selection keypad will check all boxes if empty, disabling all drink selections or clear all boxes if previously checked.
2. On returning to standby mode the selection button light will be extinguished next to any drink selections that have been disabled, indicating to the customer that the drink choice is un-available.

For machines fitted with a carbonator it is also possible to disable either the still or sparkling option for cold drinks.

3. Enter the disable selections sub-menu as previously described and using the ▼ (down) key scroll down until the required cold drink option is highlighted. Pressing the ↵ (Edit) key will disable the option, indicated by an X appearing in the box.

To completely disable the selection enter an X into both the Still and Sparkling boxes.

6.5.4 SureVend™

Entry into this menu allows the engineer to turn the SureVend™ product delivery sensor on or off.

SureVend™ Overview:

1. SureVend™ ensures that a cup is always available in the cup station before any money is collected or product delivered. The sensing system is a beam of infra-red light across the cup station that is broken by a cup as it falls into position from the cup drop unit, or by a customer placing his own mug in the dispense area.
2. The SureVend™ software monitors the cup station sensor during the time that the cup ring is operated and for three seconds afterwards. If a cup is not detected the software will then attempt to drop a cup a second and if necessary, a third time. After three sets of three failed vend attempts the cup ring is placed temporarily out of service. The machine will beep once and the LCD will display the Vend Failed message (if set to Pay Vend mode).

- Customers can now get their money back by pressing the coin return button or removing their card. The LCD will change and display the message Out of Cups Please Insert Mug. The machine remains in service but will not vend a cup from the cup drop unit.
- To clear the message and return to standby mode; open the door and press button **14** on the Service keypad. Check and if necessary, clear the cup drop unit and ensure correct operation before leaving the machine.

To configure SureVend™ proceed as follows:

- From the Product Configuration menu highlight SureVend™ and press the ← (Edit) key. By default SureVend™ is factory set to On as indicated by the status line at the bottom of the screen.

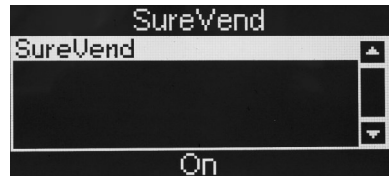
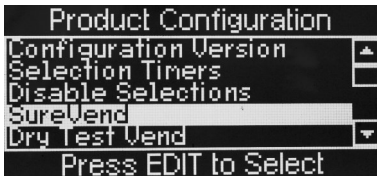

- To disable SureVend™, press the ← (Edit) key to enter the SureVend™ On/Off screen. Use the ▲(up) key to select Off (indicated by the filled radio button).
- Press the ← (Edit) key to confirm the selection and return to the SureVend™ screen. Verify that the status line at the bottom of the screen displays Off when SSureVend™ is highlighted.
- Pressing the X (Exit) key will move back to the Product Configuration screen and save the new parameter to the machines memory.

6.5.5 Dry Test Vend

This menu enables the machine to be tested/ configured without the need to be connected to the water supply.

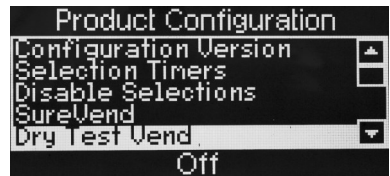

6.5.6 Water Only – No Cup

This menu enables the customer to receive Hot and Cold Water selections without the machine dropping a cup (the SureVend™ Sensor must be blocked with the customer’s mug to allow the vend to take place).

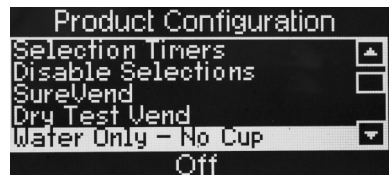

6.5.7 Cup Size Selection

This menu allows a preset set of values to be loaded for 7oz, 9oz or 12oz drinks.

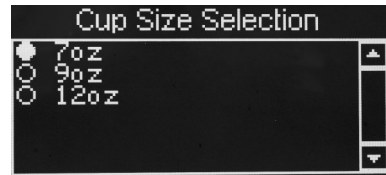
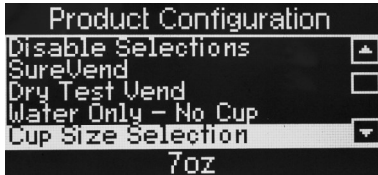

6.5.8 Cup Mechanism

This menu enables the cup drop unit to be switched on or off, the default is On. This is for users who wish to vend drinks into their own cups. SureVend™ still monitors the cup station and will not dispense drinks without a cup in the dispense area.

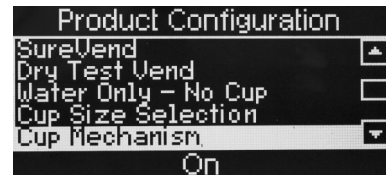

6.5.9 CupMech Cup Capacity

This enables the number of cups (0-9) that can be dispensed after the cup sensor has detected 'no cups'. This is the number of cups left below the sensor that can be used before cup turret is activated to index to the next full stack.



6.5.10 Water Module

This menu enables a slave water module to be switched on or off, the default is Off.

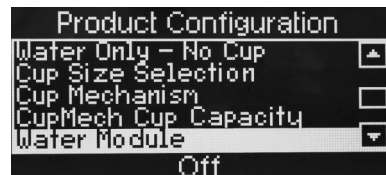

6.5.11 Low Water Reset

In normal operation a machine will only allow the boiler to fill for two minutes after which the inlet valve will be closed and the machine turned off until the machine is power cycled. If this feature is turned on the machine will allow the inlet valves to be opened every thirty minutes for a further two minutes as required without it being power cycled.

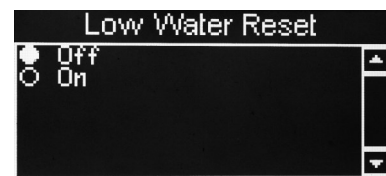

6.5.12 Water Compensation (CoEx machines only)

This sub menu allows the engineer to set the B2C water system to vend the correct amount of water for individual site operating conditions.

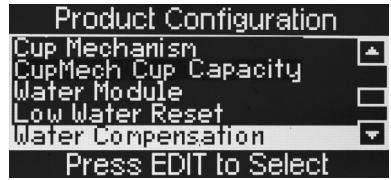

Important: the Grinder Calibration must be carried out before setting the Water Compensation.

The goal is to vend the programmed amount of water (in Selection Timers) during a vend, more or less will be vended by increasing or decreasing the numeric value. FB Compensation relates to low pressure drinks, Esp Compensation relates to high pressure drinks and is set in exactly the same way.

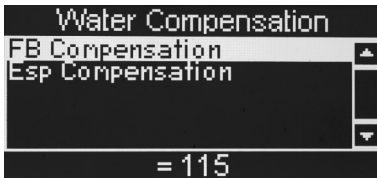

6.5.13 Heater Tank Set-Up

This allows the heater tank target temperature and minimum vend temperature to be set. (The Minimum Vend Temperature can be increased but not reduced below the default of 75 degrees).

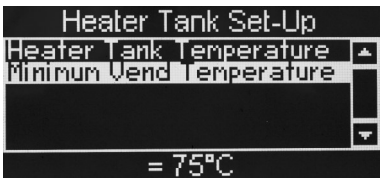
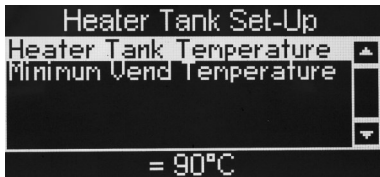

6.5.14 Heater Tank Set-Up 2

On B2C (bean to cup) models with two boilers there is an option to set up the temperatures in the second Heater Tank.

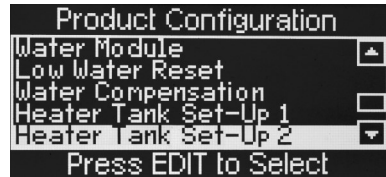

6.5.15 Brewer Setup (CoEx Machines only)

This sub menu is used to set up the various features used on a CoEx brewer.

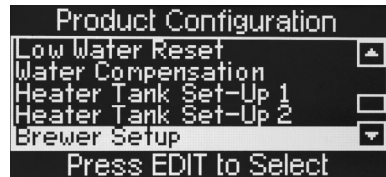

6.5.15.1 Grinder Calibration

This needs to be set so that the gram throw set in selection timers is delivered. Follow the on screen instructions.

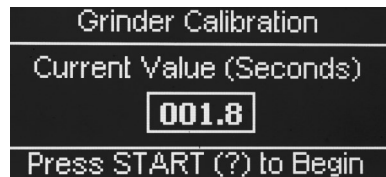
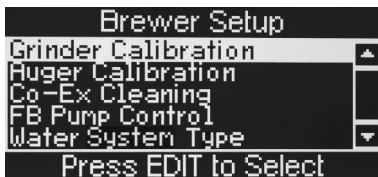

6.5.15.2 Auger Calibration

This needs to be set so that the gram throw set in selection timers is delivered. Follow on screen instructions.

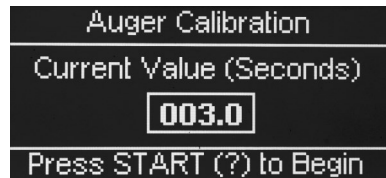
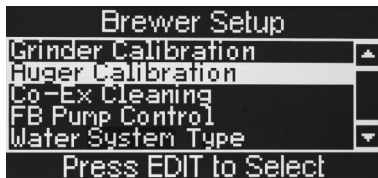

6.5.15.3 Co-Ex Cleaning

This menu allows the cleaning options for the CoEx system to be set.

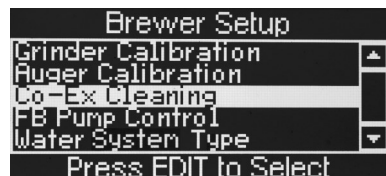

6.5.15.3.1 Perform Co-Ex Clean

This performs the same function as pressing button 11 on the Service Keypad ie performs a CoEx clean routine.

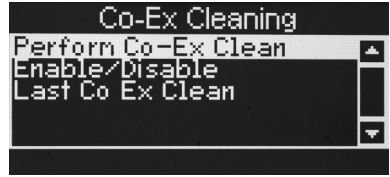

This initial clean starts the cleaning routine 10 day cycle. After 7 days a warning message is displayed, if this is ignored for a further 3 days the B2C and freshbrew coffee drinks will be disabled. It is important that the time and date have been set correctly.

6.5.15.3.2 Enable/Disable

This can disable the 10 day cycle meaning the brewer does not have to be cleaned every 10 days resulting in a poor quality drink and possible failures the brewer system.

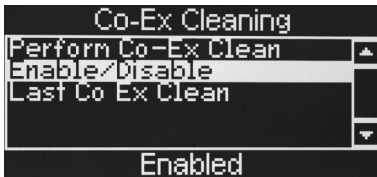

6.5.15.3.3 Last Co-Ex Clean

This shows the time and date of the last successful Co-Ex cleaning cycle.

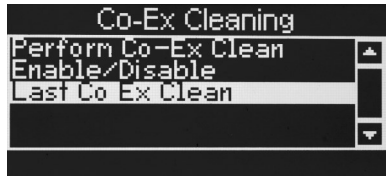

6.5.15.4 FB Pump Control

If set to Low will prevent premature switching of the filter head.

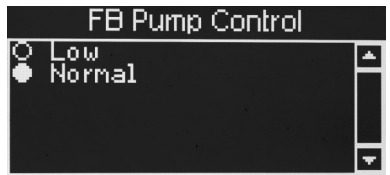
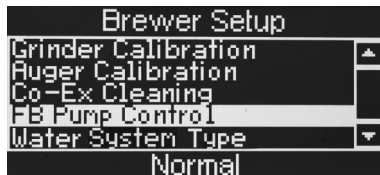

6.5.15.5 Water System Type

This indicates the water system installed in the machine, either a single or dual pump system.

Important: This is set at the time of machine configuration and must not be changed.

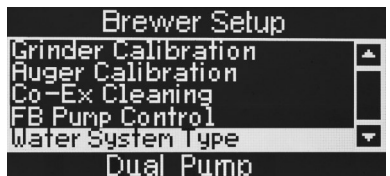

6.5.16 Syrup Cleaning

This will flush the syrup system. (follow on screen prompts).

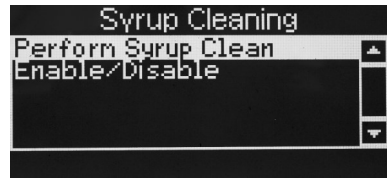

6.5.17 Brewer Waste Management

If this feature is turned **On** it will disable the fresh brew drinks after a predetermined number of brewer vends.



6.5.17.1 Brewer Waste Management

If this feature is turned on the operator must press button **12** on the service keypad every time they empty the brewer waste bucket.

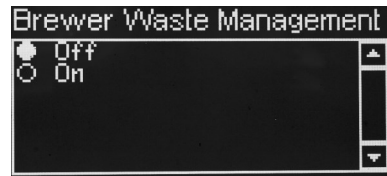
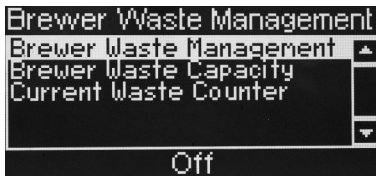

6.5.17.2 Brewer Waste Capacity

The number of vends before the brewer waste bucket needs to be emptied can be changed at this time.

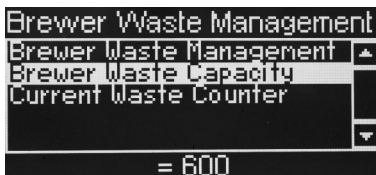

6.5.17.3 Current Waste Counter

The current waste counter can be seen at the bottom of this screen.

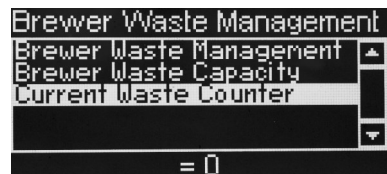

6.5.18 Water Filter Management

This menu enables an indication of when the water filter requires changing.

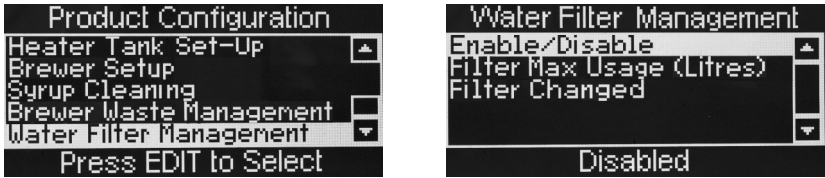

1. Filter management can be Enabled/Disabled as required.
2. The maximum number of litres through the filter can be specified, the default is 5000 litres.

When this number is reached the machine is still usable but an alternating message 'Water Filer Change Required' is displayed on the standby screen.

3. The litre count can be reset to zero after the filter has been changed.

A warning is displayed to indicate you are about to reset the usage monitoring.

6.6 Free Vend

Here the Free Vend feature can be turned **On** or **Off**.

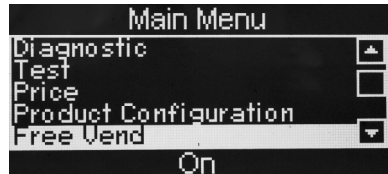

6.7 Coins In/Out Menu

(Only seen when the machine has a MDB coin mech enabled)

This option is where coins must be loaded and ejected from the coin mech. it will also show the current level and value of coins in each of the tubes.

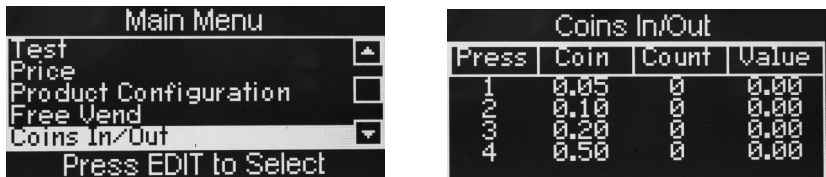

6.8 System Settings Menu

This menu allows the engineer to set information relevant to the machine and its location, the current time and date, DTS information, backup and restore machine software, view the machine and I/O board software versions installed and set temperature and idle screen display options.

N.B. Custom Messages is not supported at this time.

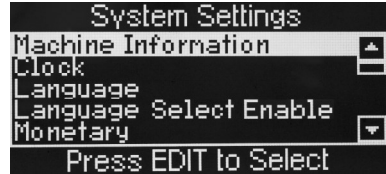

Data Transfer
Serial Flash
Backup/Restore Data
RAM Clear
Screen Contrast
Software Version
IO Board Software
Temperature Units
Idle Screen Options
Custom Messages
Service-mode Timeout
Dispense Head Position
Key-Less Transitions

6.8.1 Machine Information

This sub-menu allows the engineer to set an identification for the machine and its location.

1. From the Systems Settings menu highlight Machine Information and press the ↵ (Edit) key. The LCD will display the screen as shown opposite. To view the Machine ID press the ↵ (Edit) key. This information is only seen on data printouts.

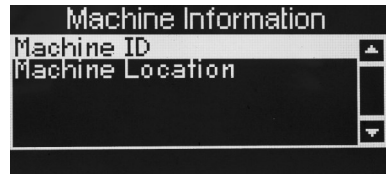

2. When complete, press the X (Exit) key to return to the Machine Information menu screen. If necessary press the ▼ (down) then ↵ (Edit) keys to highlight then enter the Machine Location screen. When complete press the X (Exit) key.

The keys are configured as follows:

1 = , . ? ; : " ' 1	2 = a b c 2
3 = d e f 3	4 = g h i 4
5 = j k l 5	6 = m n o 6
7 = p q r s 7	8 = t u v 8
9 = w x y z 9	0 = - \ \$ @ % # & 0

To change between lower and upper case press the **START/?**

6.8.2 Clock

The machine displays the current time in either 12 or 24 hour format.

Upon entry to the System Settings menu, the Clock sub menu is highlighted. Press the ↵ (Edit) key to access the Clock sub menu screen. This menu allows the engineer to set the date, time and daylight saving via 3 separate sub menus.

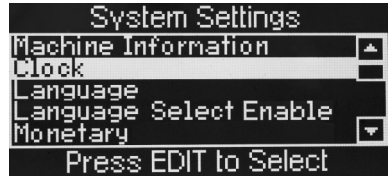

N.B. The current date, time and daylight saving (when highlighted) held in the machines memory are displayed in the status line at the bottom of the screen.

1. **Date:** Press the ↵ (Edit) key to enter the Date menu. The date is displayed in day, month, year format. To set the date, e.g. 27th January 2013, press the sequence 2-7-0-1-1-3 using the appropriate number keys on the drink selection keypad.

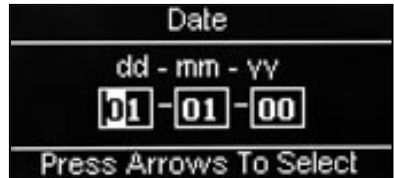

Pressing the ↵ (Edit) key will move back to the Clock menu screen and save the date to the machines memory. Confirm that the status line at the bottom of the screen displays the correct date when Date is highlighted.

N.B. Press Start To Change Mode. Pressing the **START/?** key on the drink selection keypad allows the date to be displayed in mm – dd – yy format.

2. **Time:** From the Clock menu screen press the ▼ (down) key to highlight the Time menu followed by the ↵ (Edit) key. The LCD will display the screen as shown opposite. By default the time is displayed in 24 hour format. To enter a time of 10:30 PM press the sequence 2-2-3-0 on the drink selection keypad.



Press the ↵ (Edit) key to return to the Clock menu and save the new time. Confirm that the status line at the bottom of the screen displays the correct time when Time is highlighted.

N.B. When set to 12 hour format, the program enables the engineer to set the numbers 0 or 1 in the first field. Once the number 24 has been entered to indicate 24 hour format, he engineer can reset the first two values to reflect 10:30 PM in 24 hour format e.g. 22:30.

3. **Daylight Saving:** From the Clock menu screen press the ▼ (down) key to highlight the Daylight Saving menu followed by the ↵ (Edit) key. The LCD will display the screen as shown opposite.



By default daylight savings time is set to Off. To choose one of the available options, press the ▲(up) or ▼(down) key until selected (indicated by the filled radio button) followed by the ↵ (Edit) key. Ensure that the required setting is displayed in the status line at the bottom of the screen.

Press the X (Exit) key to return to the main menu.

6.8.3 Language

This menu allows the language for the text to be chosen.

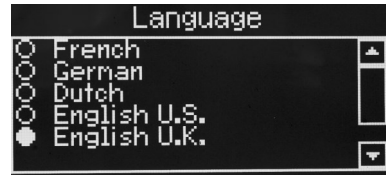
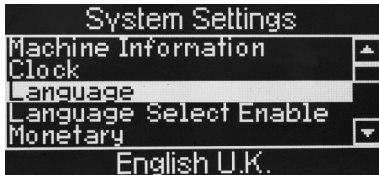

6.8.4 Language Selection Enable

This enables the customer to select a language when selecting a drink.

This is a dual language feature where a selection button (bottom left) is assigned to 'change language'. The language can be selected from the default list.

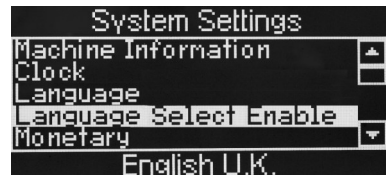

6.8.5 Monetary

This allows the setting relating to the coin card and note reader to be setup.

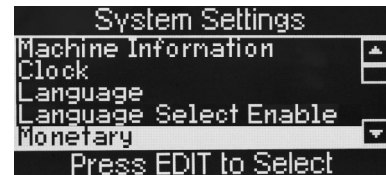

6.8.5.1 Coin Mechanism

Select the version of coin mechanism used.

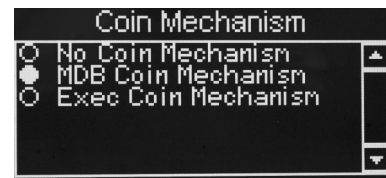
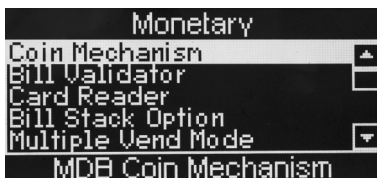

6.8.5.2 Bill Validator

Select the version of bill validator used.

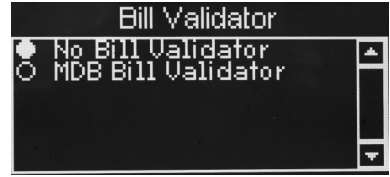
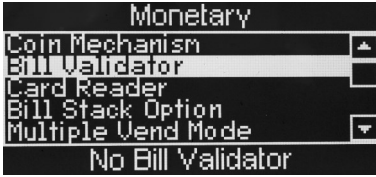

6.8.5.3 Card Reader

Select the version of card reader used.

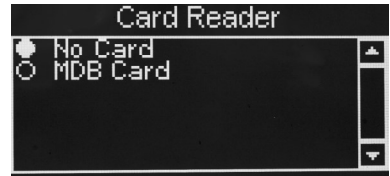
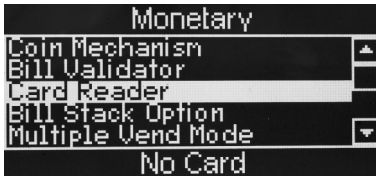

6.8.5.4 Bill Stack Option

If set to Escrow and the vend fails the note will be returned, if set to Stack and the vend fails the credit will be returned where possible as coins.

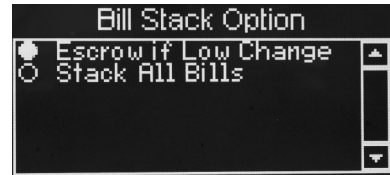
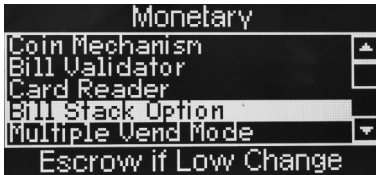

6.8.5.5 Multiple Vend Mode (MDB only)

If set to Single Vend, change will be given after the vend, if set to Multi Vend, additional vends can be selected until there is insufficient credit, the reject button must be pressed to obtain change.

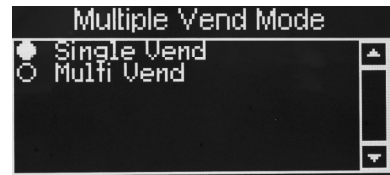
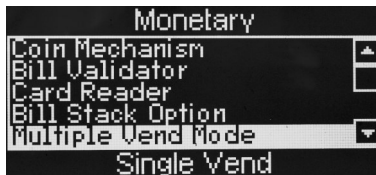

6.8.5.6 Change Without Purchase (MDB only)

The value of change which will be given without a selection being made.

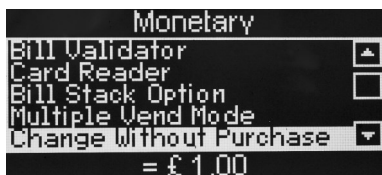

6.8.5.7 Low Change Message (MDB only)

When this value of coins in the change tubes is reached a Use Exact Change message is displayed and coins higher than the value set in Accept on Low Change are rejected.

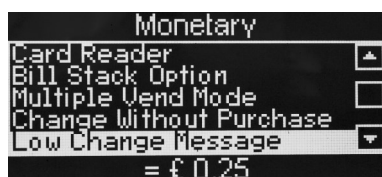

6.8.5.8 Accept on Low Change (MDB only)

The value of the highest coin to be accepted when the Use Exact Change message is being displayed.



6.8.5.9 Credit for Failed Vend (MDB only)

If the vend fails the machine can Hold Credit or Return Change.

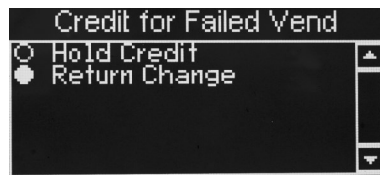
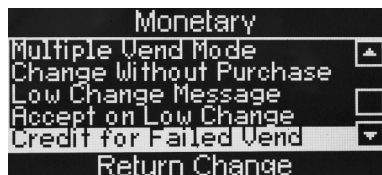

6.8.5.10 Display Coin Set

The standby screen will display a message requesting the coins preferred for use in the machine.



50p to £1
 Card
 Key
 Money
 Token

6.8.6 Data Transfer

Entry into this menu allows the engineer to configure the machine in order to send audit data relating to sales and events stored in the machines memory to a data carrier or other device.

Data Transfer Standard (EVA-DTS) - Overview: The standard makes it possible to transfer information from vending machines/payment systems to PC-based accounting/management systems and/or the opposite way. It is important that all suppliers of vending machines and payment systems agree to a common standard for the Electronic Data Transfer, because only this way the engineer can be sure that all his equipment can be read out and programmed by means of the same handheld terminal.

1. **DTS Standby Mode:** Scroll down and highlight DTS from the System Settings menu. Press the ↵ (Edit) key to access the menu. The LCD will display the screen as shown. The first sub-menu DTS Standby Mode is highlighted with its current state (DDCMP) shown in the bottom line.



Printer Baud Rate
 Security Codes

The machine is factory set to enable data transfer via the optical DDCMP link. To change this to the DEX setting, press the ↵ (Edit) key to access the menu and the ▲ (up) key to select DEX (indicated by the filled radio button. Press the ↵ (Edit) key to save the selection.

N.B. Even if the default is set to DDCMP, once the controller detects a DEX activity, it will automatically switch to the other mode. However, setting the default to the correct protocol will speed up response time.

The engineer can now download data from the machine by plugging a DEX enabled device into the DEX port (J36) on the I/O board, located on the rear of the door.

2. **DTS Audit List:** From this sub-menu the engineer can select which data is transferred from the machine to a DEX/DDCMP data carrier. Scroll down and highlight DTS Audit Data. Press the ↵ (Edit) key to access the menu. The LCD will display the screen as shown.



All data and events fields within a vending machine are assigned a unique code determined by the Standard. From this sub-menu the operator can choose to allow all fields to be available for download by pressing the **START/?** key or scrolling through the list and adding an **X** to the required fields.

3. **CA304 Data Type:** This sub-menu determines whether the data will be displayed as currency or numerical, for example, assuming that the value of pound coins in the machine is £3.00, when set to currency CA304 will read 300 in the DEX/DDCMP report. When set to numeric it will read 3.
4. **Data Reset Mode:** This field can be set to either AUTO or SAVE from within the sub- menu. When set to AUTO, all resettable data will be reset after a successful read.
5. **Event Reset Mode:** This field can be set to either AUTO or SAVE from within the sub- menu. When set to AUTO, all event data will be reset after a successful read.
6. **Printer Baud Rate:** This allows the operator to set the correct baud rate for a serial printer if one is to be used. It is important for this to be set correctly to ensure successful data transfer.
7. **Security Codes:** A Hand Held device can be used to collect sales data from the machine. A password is used to recognise the device on subsequent visits, if a different device is used the original password must be cleared using this option, to extract the data from the machine.

6.8.7 Serial Flash

This menu is only available when a Data Key is plugged onto J9. It allows the engineer to save and load:

- Firmware – operating system and factory default settings.
- Default Data – factory default settings.
- Configuration Data – all settings changed during programming by the engineer.
- Configuration and Sales Data – all settings changed during programming by the engineer plus sales data.
- Language Data – not used on the VOCE.

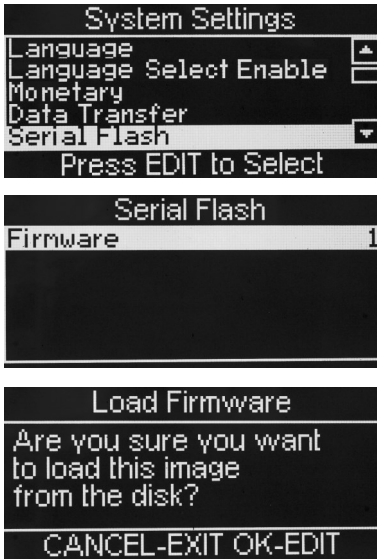

When saving Configuration Data it is also possible to edit the filename.

6.8.8 Backup/Restore Data

This menu allows the operator to manually backup information stored in the machines memory to the controller board.

N.B. It is also possible for the operator to programme Backup as a timed event, thus ensuring even greater security for the information stored in memory. This ensures that the machine can easily be restored to its last operational state should the information be lost through corruption or power failure.

1. Scroll down and highlight Backup/Restore from the System Settings menu. Press the ↵ (Edit) key to access the menu. If this is the first time that a backup has been selected the LCD will display the screen as shown.
2. Press the ↵ (Edit) key to access the menu. The LCD will display the screen as shown. To backup the memory press the ↵ (Edit) key. After a few seconds the machine will beep once and the Initialising screen will be displayed before the machine returns to standby mode, ready to vend.

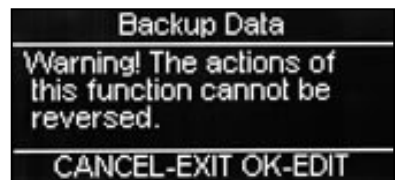
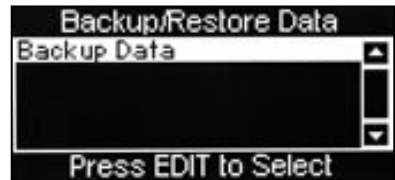

- When accessing the Backup/Restore sub-menu after backups of the memory have been made, the information changes and the operator is presented with the screen as shown. The first sub-menu, Last Backup is highlighted with the date and time this occurred displayed at the bottom of the screen.



- To restore the machines memory to the last available backup, scroll down using the ▼ (down) key, highlight Restore Data and press the ↵ (Edit) key to access the menu. The LCD will display the screen as shown.



Press the ↵ (Edit) key to restore the backed up data. After a few seconds the machine will beep once and the Initialising screen will be displayed before the machine returns to standby mode, ready to vend.

6.8.9 RAM Clear

This will delete all data and return the machine to its default settings.

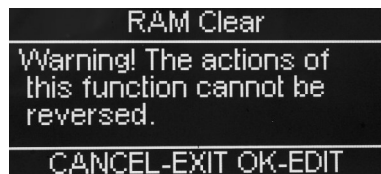
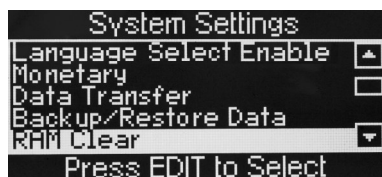

6.8.10 Screen Contrast

Allows the brightness of the screen to be adjusted.

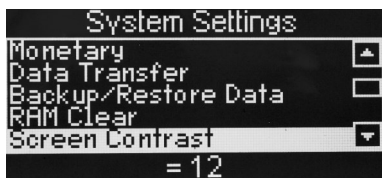

6.8.11 Software Version

The Software version menu displays the version number of the software installed and is for information only. The menu also displays the current time and date.

6.8.12 I/O Board Software

This menu displays the version number of the I/O board software installed and is for information only.

6.8.13 Temperature Units

Allows the choice between Celsius and Fahrenheit.

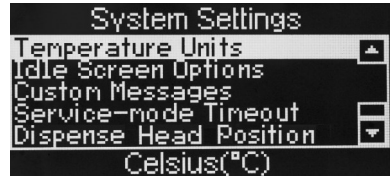

6.8.14 Idle Screen Options

This menu allows the operator to configure the LCD so that it displays either the time or the time and water temperature with the standby message when idle. To configure the idle screen options, proceed as follows:

1. From the System Settings menu press the ▼(down) key to highlight Idle Screen Options and press the ↵ (Edit) key to access the menu.
2. Press the ▼(down) key to highlight the required option, eg Time and Temp (indicated by the filled radio button). The LCD will display the screen as shown opposite. Press the ↵ (Edit) key to return to the System Settings screen.

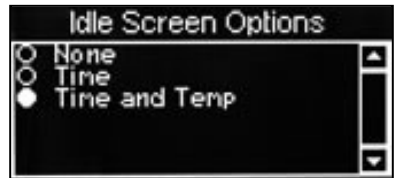

With Idle Screen Options highlighted verify that the status line confirms the option is set to Time and Temp.

3. Press the X (Exit) key until the machine exits the engineers program into standby mode. The LCD will display the standby message with the time and temp as shown.

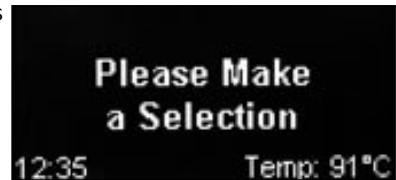

6.8.15 Custom Messages

Allows the Ready, Temporarily Out of Service, No Money Required and Please Make a Selection messages to be replaced.

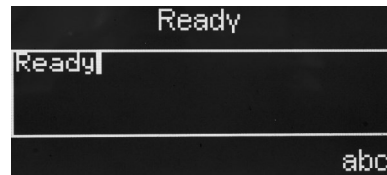
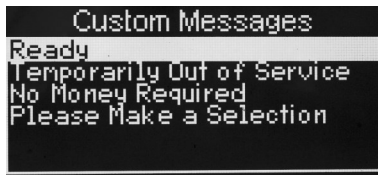
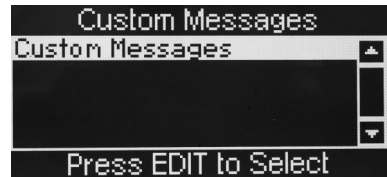
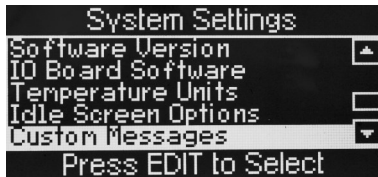

6.8.16 Service Mode Timeout

This menu allows the operator to set the time after which the machine will automatically switch from service mode to standby.

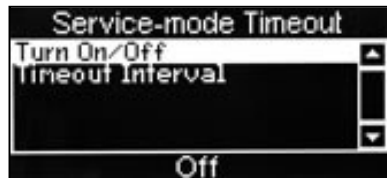

1. Select as required.



2. Enter time in minutes after which the machine will automatically switch from service mode to standby



6.8.17 Dispense Head Position

This enables the position of the Dispense Heads after a vend to be set.

1. Select as required.

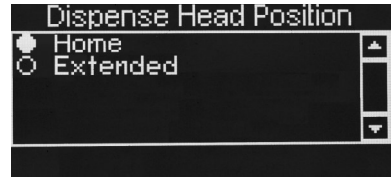

6.8.18 Key-less Transitions

This menu allows the operator to turn On/Off the feature whereby entering a code enables the Free Vend and Jug Vend features.

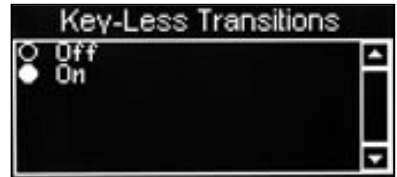

6.9 Security Codes Menu

The Engineer, Operator, Free Vend and Jug Vend PIN codes can and **SHOULD** be changed on installations.

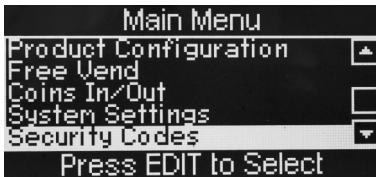



6.9.1 Time of Day Events

From this menu the operator can set up inhibited vend periods, free vend periods and discounted vend periods.

The following example describes how the operator can program the machine to free vend Instant Coffee, Cappuccino and Caffe Latte drink selections between 10:30 am and 02:30 pm on week days.

- From the Main Menu press the ▼(down) key until Timed Events is highlighted then press the ↵(Edit) key twice to access the Time of Day menu screen. The LCD will display the screen as shown.



N.B. Although event 1 is shown as Inhibit, it is possible for the operator to set event 1 as the first Free Vend or Discounted Vend period.

- Press the ↵(Edit) key to access the menu. The LCD will display the screen as shown. By default the current State is set to Off as indicated by the status line at the bottom of the screen.

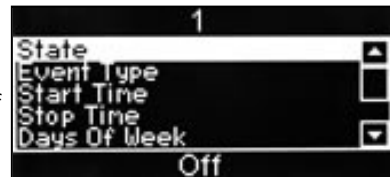

- Press the ↵(Edit) key to access the State sub menu. Using the ▼(down) key, set the state to On (indicated by the filled radio button). Press the ↵(Edit) key to return to the Event 1 screen. Verify that the status line confirms the State is set to On.



- Press the ▼(down) key to highlight Event Type and press the ↵ (Edit) key to access the menu. Using the ▼(down) key, set the Event Type to Free Vend (indicated by the filled radio button). Press the ↵ (Edit) key to return to the Event 1 screen. Verify that the status line confirms the Event Type is set to Free Vend.



- Press the ▼(down) key to highlight Start Time and press the ↵ (Edit) key. From this menu the operator sets the time at which the free vend period will start. Press the sequence 1-0-3-0, using the drink selection keypad, to set the time. If necessary use the ▲(up) or ▼(down) key until AM appears in the dotted box.



Press the ↵ (Edit) key to return to the Event 1 screen. Verify that the correct start time is displayed in the status line at the bottom of the screen.

- Press the ▼(down) key to highlight Stop Time and press the ↵ (Edit) key. From this menu the operator sets the time at which the free vend period will end. Press the sequence 1-4-3-0, using the drink selection keypad, to set the time.



- Press the ↵ (Edit) key to return to the Event 1 screen. Verify that the correct stop time is displayed in the status line at the bottom of the screen.

- Press the ▼(down) key to highlight Days Of Week and press the ↵ (Edit) key. The operator can now set the days on which the free vend period will take place. Upon entry to the sub menu, the first day, Monday will be highlighted with an empty box. Pressing the ↵ (Edit) key will select the day, indicated by an X appearing in its adjacent box.



Using the ▼(down) key and the ↵ (Edit) key, highlight and select additional days of the week that the free vend period will take place. When complete press the X (Exit) key to return to the Event 1 screen.

9. Press the ▼(down) key to highlight Selections and press the ↵ (Edit) key. The operator can now set the drink selections that will be available during the free vend period. Upon entry to the sub menu, the Freshbrew Coffee selection will be highlighted with an empty box.

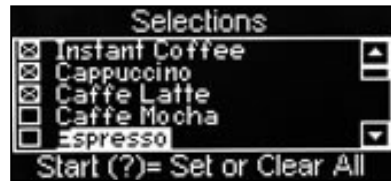

Pressing the ↵ (Edit) key will select the drink, indicated by an X appearing in its adjacent box.

Using the ▼(down) key and the ↵ (Edit) key, highlight and select additional drink selections that will be available during the free vend period.

10. Press the X (Exit) key three times to return to the Timed Events Menu.

Using the previous sequence the operator can quickly and easily set up additional free vend periods, inhibit vend or discount vend periods if required.

11. When setting up a discount price period it is necessary for the operator to enter a value for the discount. Follow the procedure as described previously to enter a discount vend period and set the state, start time, stop time and days of the week that the event will occur.

12. The operator can now enter a Discount menu in order to enter a discount value as a percentage (%). The LCD will display a screen similar to the one shown opposite. With Discount highlighted, press the ↵ (Edit) key to access the Discount screen.

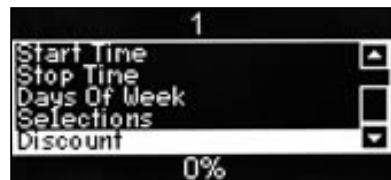

13. To enter the discount value, e.g. 50%, press the sequence 5-0 using the appropriate number keys on the drink selection keypad. Press the ↵ (Edit) key to return to the 11 (Discount) screen and verify that the status line displays the discount percentage value entered.



14. Press the X (Exit) key three times to return to the Main Menu screen.

N.B. When machine is fitted with a coin mechanism, please ensure that discount value entered can be supported by the coin tubes.

6.9.2 Sanitation Events Menu

This sub menu allows the operator to select periods when the machine will automatically flush through the water system via the 12 flush periods available. The default setting for all flush periods is Off.

1. From the Main Menu press the ▼(down) key until Timed Events is highlighted then press the ↵ (Edit) key.
2. Once in the Timed Events menu press the ▼(down) key to highlight Sanitation Events Menu then press the ↵ (Edit) key. The LCD will display the screen as shown.

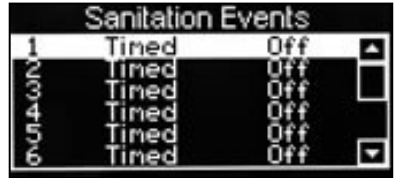

The following example describes how the operator can program a timed event to flush the water system at 07:00 am every day.

1. To set up the first timed flush, press the ↵ (Edit) key to access the 1 Timed sub menu. The LCD will change and display the screen as shown.
By default the current State is set to **Off** as indicated by the status line at the bottom of the screen.

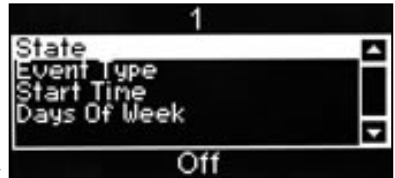

2. Press the ↵ (Edit) key to access the State sub menu. Using the ▼(down) key, set the state to **On** (indicated by the filled radio button). Press the ↵ (Edit) key to return to the 1 (Timed) screen. Verify that the status line confirms the State is set to **On**.

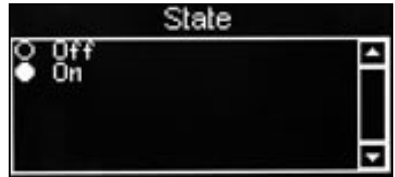

3. Press the ▼(down) key to highlight Event Type. By default the event is set to Timed as indicated by the text displayed in the status line at the bottom of the screen. Therefore it is not necessary for the Operator to enter this sub menu.



4. Press the ▼(down) key to highlight Start Time and press the ↵ (Edit) key. From this menu the operator sets the time at which the sanitation event will start. Using the drink selection keypad, press the sequence 0-7-0-0 to set the time. If necessary use the ▲(up) or ▼(down) key until AM appears in the dotted box.



5. Press the ↵ (Edit) key to return to the 1 (Timed) screen. Verify that the correct start time is displayed in the status line at the bottom of the screen.
6. Press the ▼ (down) key to highlight Days Of Week and press the ↵ (Edit) key. From this menu the operator can set the days on which the sanitation event will take place. To select every day (Monday - Sunday), press the **START/?** key on the drink selection keypad. The program automatically places an **X** in every box indicating that each day is selected.

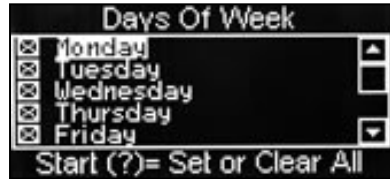

N.B. To select individual days, scroll through the menu using the ▲ (up) or ▼ (down) keys until the required day is highlighted. Press the ↵ (Edit) key to select the day, indicated by an **X** appearing in its adjacent box.

7. Press the **X** (Exit) key three times to return to the Timed Events Menu. Using the sequence described above the operator can quickly and easily set up additional sanitation event periods for the machine.

It is also possible for the operator to program up a post vend sanitation event. The following example describes how the operator can program a post vend event to flush the water system 12 minutes after each vend.

1. From the Main Menu press the ▼ (down) key until Timed Events is highlighted then press the ↵ (Edit) key. Once in the Timed Events menu press the ▼ (down) key to highlight Sanitation Events Menu then press the ↵ (Edit) key. Press the ▼ (down) key until the first Post Vend event is highlighted. The LCD will display the screen as shown.

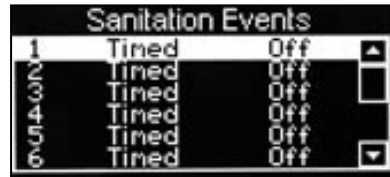

2. With Post Vend highlighted, press the ↵ (Edit) key to access the 7 Post Vend sub menu. The LCD will change and display the screen as shown. By default the current State is set to **Off** as indicated by the status line at the bottom of the screen.

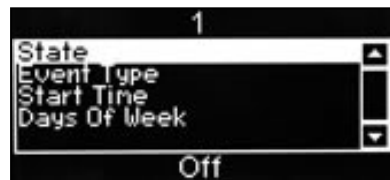

3. Press the ↵ (Edit) key to access the State sub menu. Using the ▼ (down) key, set the state to **On** (indicated by the filled radio button). Press the ↵ (Edit) key to return to the 7 (Post Vend) screen. Verify that the status line confirms the State is set to **On**.



4. Press the ▼(down) key to highlight Event type. By default the event is set to Timed as indicated by the text displayed in the status line at the bottom of the screen. Therefore it is not necessary for the operator to enter this sub menu.



5. Press the ▼(down) key to highlight Delay. The status line indicates the factory default delay which is set to 0.1hrs (6 minutes). To change the value so that the machine will self clean 12 minutes after a drink is vended press the ↵ (Edit) key to access the Delay sub menu. The LCD will display the screen as shown.



Using the drink selection keypad, press the sequence 0-0-2 to set the new delay.

Press the ↵ (Edit) key and verify that the status line confirms that Delay (when highlighted) is set to 0.2hrs.

6. Press the X (Exit) key three times to return to the Timed Events Menu. Using the sequence described above the operator can quickly and easily set up additional post vend sanitation event periods for the machine if required.

N.B. A sanitation event, either timed or post vend, dispenses water into the waste bucket. If the waste bucket reaches its full limit the machine will be “Out Of Service”

6.9.3 Backup Events Menu

This sub menu allows the operator to program the machine to perform an automatic backup of all user configurable settings and sales data stored in its memory. The default setting for Backup Events is Off.

1. From the Main Menu press the ▼(down) key until Timed Events is highlighted then press the ↵ (Edit) key.
2. Once in the Timed Events menu press the ▼(down) key twice to highlight Backup Events Menu then press the ↵ (Edit) key. The LCD will display the screen as shown.
3. Press the ↵ (Edit) key to access the 1 Backup Data sub menu. The LCD will change and display the screen as shown. By default the current State is set to **Off** as indicated by the status line at the bottom of the screen.



- Press the ↵ (Edit) key to access the State sub menu. Using the ▼ (down) key, set the state to **On** (indicated by the filled radio button). Press the ↵ (Edit) key and verify that the status line confirms the State is set to **On**.



- Press the ▼ (down) key to highlight Start Time and press the ↵ (Edit) key. Using the drink selection keypad, set the time at which the Backup event will start.



- Press the ↵ (Edit) key and verify that the correct start time is displayed in the status line at the bottom of the screen.

- Press the ▼ (down) key to highlight Days Of Week and press the ↵ (Edit) key. From this menu the operator can set the days on which the Backup event will take place. To select everyday (Monday - Sunday), press the **START/?** key on the drink selection keypad. The program automatically places an **X** in every box indicating that each day is selected.

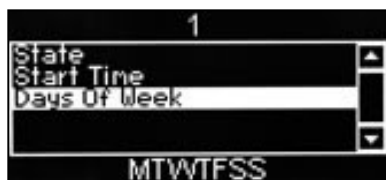

N.B. To select individual days, scroll through the menu using the ▲ (up) or ▼ (down) keys until the required day is highlighted.

- Press the ↵ (Edit) key to select the day, indicated by an **X** appearing in its adjacent box.



6.9.4 Energy Saving Events Menu

This sub menu enables the Operator to program in periods when the machine can be in an energy saving mode. In this mode the water in the boiler is not maintained at the normal vend temperature, but at a lower temperature of 68°C.

During the Energy Saving periods programmed into the machine, vends can still be dispensed, although none of the drink section buttons are illuminated and the message "Power Saving Mode" is displayed on the LCD. By pressing any one of the buttons on the keypad the LCD message changes to "Water Tank Heating". The machine reverts back to "Power Saving Mode" ten minutes after the last vend, if still within the Energy Saving Events period. The default setting for these Events is Off.

1. From the Main Menu press the ▼(down) key until Timed Events is highlighted then press the ↵ (Edit). Press the ▼(down) key three times to access the Energy Saving Events menu screen. The LCD will display the screen as shown.

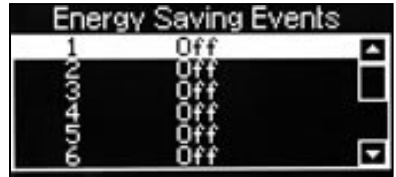

2. Press the ↵ (Edit) key to access the menu. The LCD will display the screen as shown. By default the current State is set to **Off** as indicated by the status line at the bottom of the screen.



3. Press the ↵ (Edit) key to access the State sub menu. Using the ▼(down) key, set the State to **On** (indicated by the filled radio button). Press the ↵ (Edit) key to return to the Event 1 screen. Verify that the status line confirms the State is set to **On**.



4. Press the ▼(down) key to highlight Start Time and press the ↵ (Edit) key. From this menu the operator sets the time at which the Energy Saving period will start. Enter the start time in the sequence 1-7-3-0, using the drink selection keypad.



5. Press the ↵ (Edit) key to return to the Event 1 screen. Verify that the correct start time is displayed in the status line at the bottom of the screen.

6. Press the ▼(down) key to highlight Stop Time and press the ↵ (Edit) key. From this menu the operator sets the time at which the Energy Saving period will end. Enter the time using the drink selection keypad. If necessary use the ▲(up) or ▼(down) key to display AM or PM as required.



7. Press the ↵ (Edit) key to return to the Event 1 screen. Verify that the correct stop time is displayed in the status line at the bottom of the screen.

- Press the ▼(down) key to highlight Days Of Week and press the ↵(Edit) key. The operator can now set the days on which the Energy Saving period will take place. Upon entry to the sub menu, the first day, Monday will be highlighted with an empty box. Pressing the ↵(Edit) key will select the day, indicated by an X appearing in its adjacent box.

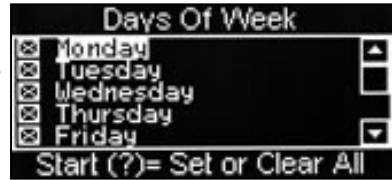

Using the ▼(down) key and the ↵(Edit) key, highlight and select additional days of the week that the Energy Saving period will take place. When complete press the X (Exit) key to return to the Event 1 screen.

Tip: To set the required days/selections quickly, press the **START** key to check all boxes, then using the ▼(down) key, scroll and highlight the days/selections not required and press the ↵(Edit) key to remove the X from the corresponding box.

- Press the X (Exit) key three times to return to the Timed Events Menu.

Section 7 - Technical Information

7.1 Water Services

The mains water supply provides water for the heater tank and the pressure system fitted to Espresso (B2C) machines. Water enters at the rear of the machine through a solenoid operated inlet valve operating at 24v DC, which opens or closes the water supply as required.

7.2 Hot Water System

7.2.1 General

1. Water is heated in the heater tank to the required temperature by a heating element rated at 2.4 Kilowatts. The mains voltage required for the element is switched by a solid state relay, controlled by the vending machine controller via an analogue signal transmitted by the thermistor probe.
2. The water level inside the heater tank is controlled by a water level probe. When the water drops below the required level, the controller board operates the mains water inlet valve until the required water level is restored.
3. A series of 24v DC control valves are mounted on the outside of the heater tank. These supply heated water to each of the mixing stations where ingredients are added to make the drink. The “hot water” valve dispenses straight into the cup.
4. Should the inlet valve fail (or mains water supply be disabled), the controller board will detect a fault after the inlet valve ‘open’ signal has been active for 2 minutes and the required water level has not been reached.
5. At this point the keypad will be disabled, all outputs from the controller board (including the heater element) will be switched off.

7.2.2 B2C Machines

The water system fitted to B2C machines is described in detail in this manual , refer to Section 8.2 - System Overview for full details.

7.3 Ingredient Dispense

1. The ingredients required for making up either an instant or freshbrew drink are contained in ingredient canisters and are dispensed by means of an auger located in the base of each canister. Each auger is driven by a 24v DC motor.
2. The amount of product dispensed by each canister is controlled by the vending machine controller and may be adjusted via the Selection Timers menu , refer to the Engineers Program – Section 6.5.2 for full details.
3. The required ingredients for each vend are delivered to a mixing bowl, where they are blended with hot water by a high speed whipper prior to discharge at the dispense head.

4. To ensure a free flow of ingredient powder and granules, it is essential that they are kept completely dry. This is achieved by extracting steam from the mixing system using an extract fan. The electrical supply for the extract fan is 230v AC.

N.B. The fan runs continuously whilst the cabinet door switch is in the on position.

5. B2C machines: Coffee beans are stored in a bean container and are dispensed into the CoEx® Brewer via a 230v AC grinder located under the bean container outlet.

The amount of beans dispensed from the container is controlled by the vending machine controller and may be adjusted via timing constraints set in the Engineers Program.

7.4 Mixing System

1. The mixing system utilises a 24v DC 13,000 RPM motor assembly and mixes ingredient with hot water from the heater tank to make a drink.
2. The mixing units are front mounted and secured by a single fixing screw. For servicing, the complete unit can be quickly and easily removed from the front of the machine.

7.5 Moving Dispense Head

1. Voce machines are fitted with a moving dispense head mechanism. This allows for a quicker and more direct cup drop and also helps to prevent cross contamination of drinks. The head features two separate dispense positions depending upon the drink being dispensed.
2. The mechanism is operated by a 24v DC 50 RPM motor. The motor is connected to a pinion which engages with a rack on the dispense arm. This mechanism is used to move the dispense head backwards and forwards.
3. A micro switch, fitted to the rear of the dispense head chassis detects the home position (head withdrawn/not dispensing). An optical sensor is also fitted and this works in conjunction with a decoder bracket attached to the rack to determine the position of the dispense head.
4. A moulded dispense head mounted at the front of the unit connects the tubes from the various mixing systems, brewers and hot water, to separate dispense nozzles.

N.B. Dispense pipe lengths are shown on page 95.

7.6 Cup Dispense Unit

1. Cups (either paper or plastic) are stored in tubes which are located above the cup dispense unit. The unit incorporates a 24v DC, motor for Indexing the correct turret over the cup drop unit as required.
2. The cups are separated and 'dropped' by a cup ring. The cup ring comprises six separator cams operated by a 24v DC motor, which is controlled by the vending machine controller.

3. The cup level is monitored by an electronic system. An infrared LED (cup sensor transmitter) is positioned in the cup assembly above the cup splitter, with an infrared detector (cup sensor receiver) mounted directly opposite.
4. The light emitted by the LED is detected when NO CUPS are present. With a stack of cups present, the beam is broken. As the cups drop below the LED, transmitted light is detected. If this is the case, the controller will index the cup tubes until a full stack is located. A turret location micro- switch ensures that the cup tubes stop centrally over the cup ring.

N.B. The turret motor will run until the next stack is deposited into the cup splitter, which breaks the LED beam, and the cup stack micro switch returns to its normally open state. The motor will run until it either finds the next stack or all the turret extrusions have been checked. If no cups are present the “Out of Cups Please Insert Mug” message is displayed on the LCD.

5. The cup stack index motor is protected by a time-out feature. The motor will rotate for a maximum period of 60 seconds. If at the end of this period no cups have been detected the LCD will display the “Out of Cups” message.

7.7 Waste Level Probes

1. The waste level probes, positioned in the waste bucket, detect the water level in the bucket.
2. The system consists of two probes in a moulded body. When the water level is high enough that both of the probes are immersed in the water a message is displayed on the LCD indicating the waste bucket is full and the machine is disabled. The machine will remain in this state until the waste bucket has been emptied.

7.8 Oltre Brewer

1. Machines may be fitted with either one or two continuous belt Oltre brewers. The chamber, base plate, filter belt and outlet elbows are different depending on whether you are vending leaf tea or ground coffee.
2. Two 24v DC 30rpm motors are used on each of these brewers, one to raise and lower the brewer chamber the other to advance the filter belt. A cam operated micro switch signals to the Main Controller whether the chamber is open or closed.

7.8.1 Coffee Brewing

1. The coffee outlet elbow and baseplate are colour coded yellow and the belt is tan.
2. The chamber clamps down onto the base plate and filter, water and coffee is then dispensed. After the brew time (set in program) has elapsed a 24v DC peristaltic pump draws the coffee liquor through the filter and is pumped to a whipper chamber where it can be whipped if required before being delivered into the cup.
3. The chamber now lifts and the second motor drives the filter belt and the waste is scraped into the waste bucket.

7.8.2 Tea Brewing

1. The tea outlet elbow and baseplate are colour coded blue and the belt is white.
2. The chamber clamps down onto the base plate and filter, water and tea leaves are then dispensed. Gravity draws the tea through the filter and it is delivered into the cup.
3. The chamber now lifts and the second motor drives the filter belt and the waste is scraped into the waste bucket.

7.9 CoEx® Brewer (B2C Machines)

The unique CoEx® combined coffee and espresso brewer provides both freshly brewed coffee along with fresh coffee from beans through the same unit. The unit is driven by a 24v DC, 13 RPM motor, controlled by a micro switch. The switch sends logic signals to the controller during vend and initialise operations, indicating its position.

Please refer to Section 9 for full details of the CoEx® brewer and its operation.

7.10 Power Supply Unit

1. The power supply unit (PSU) provides power to the machine. It is mounted in the top right hand side of the machine and can be accessed by removing the top RH panel.
2. The PSU converts 230v AC to 24v DC to run the valves, whipper motors, ingredient motors, brewers, etc. fitted to the machine. The solid state relay, mounted on the PSU chassis, uses a 24v DC switching circuit to provide 230v AC for the heater element.
3. The Input/Output (I/O) board, mounted on the PSU chassis, utilises signals from the main controller in order to operate valves, whipper motors, the dispense head motor, ingredient motors, brewer motors, etc.
4. The PSU houses 2 fuses (3 for machines with refrigeration units fitted).
 - Heater, 12 amp (T) (ceramic) - Heater Tank, Pressure Boiler, B2C Models
 - Auxiliary components and PSU, 4 amp (glass)
 - 240v Cold Unit, 4 amp (T) (glass).

Early machines had separate fuses for the Pressure Boiler (12A T) and also for the PSU (4A T).

7.11 Mains Filter

A mains filter, mounted on the rear panel, prevents spurious voltages generated by the machine from reaching the mains supply.

7.12 Coin Mechanism Transformer (Optional Extra)

The coin mechanism transformer converts 230v AC to 24v AC for Executive protocol (A) type monetary systems.

7.13 Coin and Card/Key Systems

The VOCE may be equipped with coin or card/key validation systems using either protocol 'A' or an MDB system. The coin or card/key system informs the vending machine controller of the amount of credit which has been deposited into the vending machine.

7.14 Change Giver

1. The Change Giver communicates with the vending machine controller. It will validate a coin and if accepted, send a signal indicating the amount value which has been tendered.
2. Once sufficient credit has been accumulated a vend will be permitted. Where possible the change giver will return the appropriate amount of change to the customer.

7.15 Card/Key System

1. The card system fitted to the machine communicates with the vending machine controller using the same principle as the change giver.
2. The card system informs the vending machine controller of the amount of credit on the customer's card. If there is sufficient credit for the selected drink, the vending machine controller permits a vend and informs the card system of the amount of credit to be taken from the card. The new balance will then be re-written onto the customer's card.

N.B. For full information and programming instructions for all of these systems, please refer to the user manual supplied with the validation system.

Section 8 - B2C (Espresso) System

Voce B2C machines are capable of producing high quality espresso based drinks through the unique CoEx® brewer unit either independently (Espresso, Americano), or in conjunction with soluble product (Cappuccino, Caffè Mocha etc). The machine will also vend high quality freshbrew coffee from pre-ground product.

8.1 Example Vend

When an Espresso drink is selected the following sequence occurs:-

1. The customer selects an espresso drink. Fresh beans are delivered into the grinder and the grinder is operated for a pre-determined time. Ground coffee is deposited into the CoEx® brewer.
2. The brewer moves to the vend position. The brewer motor starts running clockwise, causing the filter assembly to cover the piston chamber and the piston to move upwards, forming the ground coffee into a compressed pellet as it does so.
3. When the heater reaches the correct temperature the inlet valve is opened and the 3 bar pressure relief valve closed. At the same time the pumps will start pumping water through the system and into the brewer.
4. Whilst water is passing through the system a water flow meter will send pulses back to the main controller and the espresso selection will be delivered into the cup.
5. Once the required amount of water has been pumped through the system, the inlet valve closes and the pumps stop pumping water through the system. The brewer compresses the used coffee pellet, the pressure relief valve is opened and the espresso valve switched off.
6. The brewer motor reverses and drives the piston back up to the top of the chamber. The wiper mechanism ejects the used coffee pellet into the dry waste container and the brewer piston moves back to the stand-by position.

8.2 System Overview

Important: The machine must be operated in conjunction with a water filter of food grade quality, capable of removing temporary hardness (scale), heavy metals (lead, copper, iron, cadmium), chlorine and any organic pollutants/discolouration. Crane Merchandising Systems recommend the Brita AquaQuell water filter for use with Voce B2C machines.

8.2.1 Water Flow Diagram (B2C - Single Pump)

Key:

- 1. Module Inlet Valve
- 2. Pressure Regulator
- 3. Flow Meter
- 4. Pump
- 5. Pressure Boiler
- 6. Espresso Valve - 3 Way
- 7. Pressure Valve - 2 Way
- 8. Relief Valve - 3 Bar
- 9. Dispense Valve
- 10. Heater Tank
- 11. Water Inlet Valve
- 12. Water Filter
- 13. Non Return Valve
- 14. By Pass

Note: System shown in idle state.

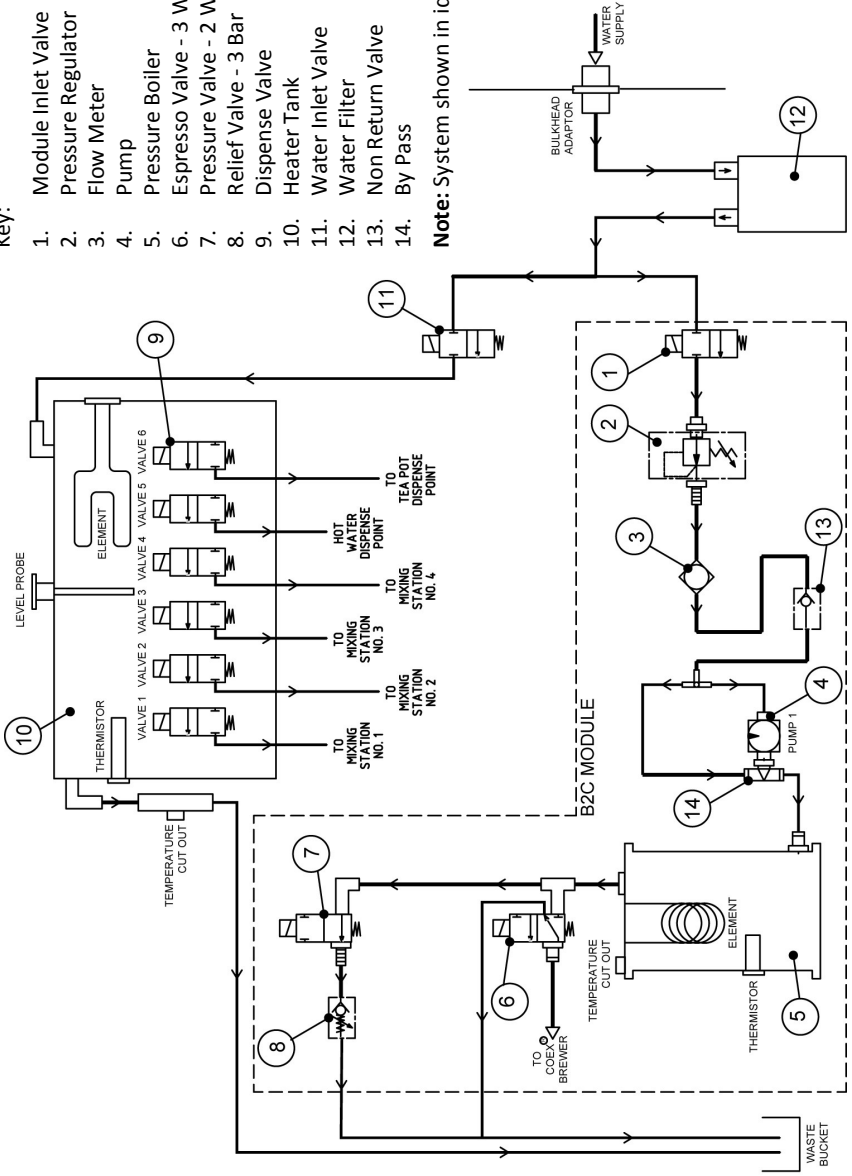

8.2.2 Water Flow Diagram (B2C - Dual Pump)

- Key:**
1. Module Inlet Valve
 2. Pressure Regulator
 3. Flow Meter
 4. Pump
 5. Pressure Boiler
 6. Espresso Valve - 3 Way
 7. Pressure Valve - 2 Way
 8. Relief Valve - 3 Bar
 9. Dispense Valve
 10. Heater Tank
 11. Water Inlet Valve
 12. Water Filter
- Note:** System shown in idle state.

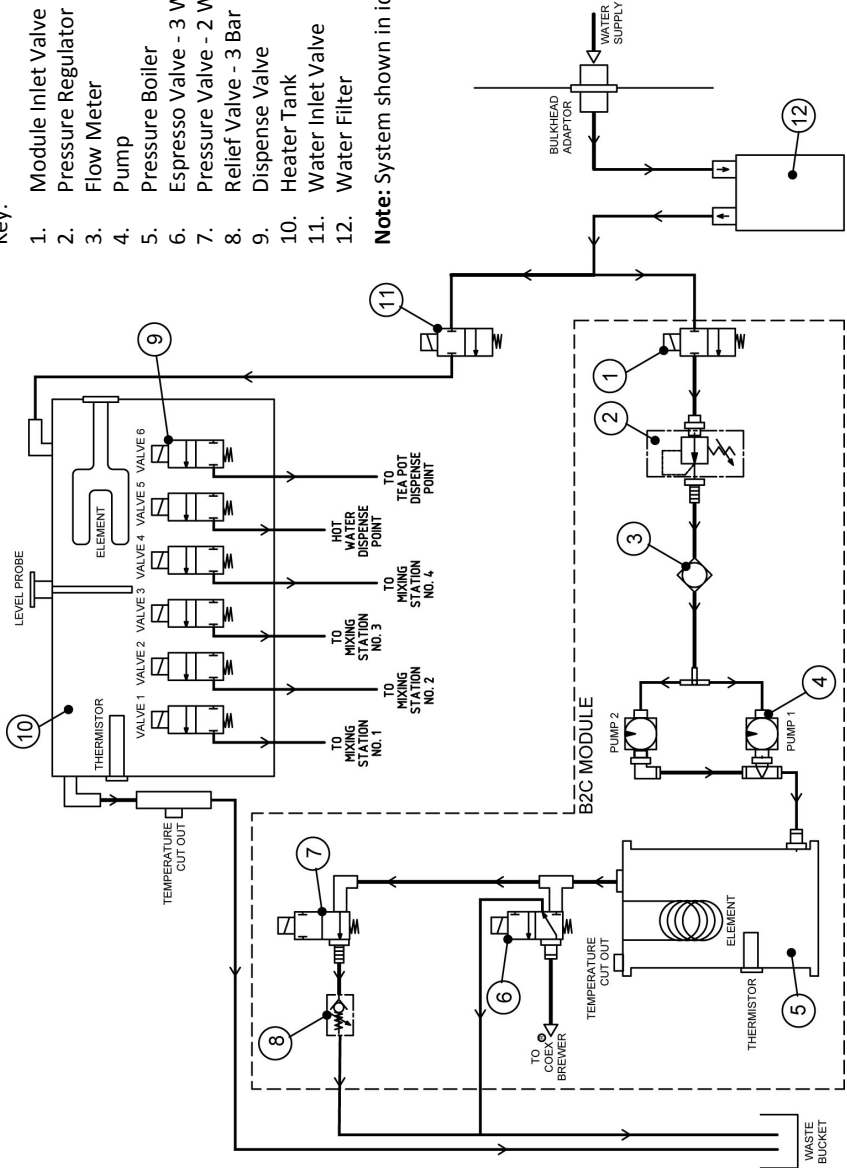

1. Water Inlet Valve

A 24V dc single solenoid water inlet valve. When a drink is selected the inlet valve is opened. At the same time the pumps are operated, pumping water through the system.

2. Reducing Valve

An inline reducing valve that maintains water pressure entering the system at 0.5 bar.

3. Flow Meter

As water flows through the system, the flow meter sends pulses back to the control board.

4. Vibration Pumps - 230V ac

When a drink is selected the pumps switch on at the appropriate moment until the required amount of water has been pumped through the system.

5. Pressure Boiler

The pressure boiler has a capacity of 350ml and is fitted with a 2kW heating element. Cold water is diffused as it enters the boiler through the lower coupling. Heated water exits the boiler through the top coupling. A resettable temperature cut-out is mounted externally near the top of the boiler as a safety feature. A thermistor is mounted in the front of the boiler to measure water temperature.

6. Espresso Valve

Supplies heated water to the CoEx[®] brewer when an espresso or freshbrew drink has been selected.

7. Pressure Valve

This valve is normally open exposing the system to the 3 bar mechanical relief valve. It is closed during vends to allow higher pressures to be achieved within the system.

8. Relief Valve - 3 Bar (Mechanical)

The 3 bar pressure valve is a mechanical safety valve. The valve allows for heat expansion while the machine is in stand-by mode.

9. Grinder Mechanism (Not Shown On Water Flow Diagram)

The grind mechanism consists of a 230V ac conical grinder with a manual adjustment. When an espresso based drink is selected the grinder will run for the programmed time, grinding beans and feeding the brewer at the same time. The grinder is fitted with a manual adjusting mechanism which allows the engineer to vary the size of the ground coffee in order to satisfy customers' taste preferences.

10. CoEx[®] Brewer (Not Shown On Water Flow Diagram)

The brewer unit is capable of receiving between 5 and 9 grams of ground coffee. Once the coffee has been ground and dispensed into the brewer unit, the 24V dc brewer motor drives the brewer to the vend position using the current sensing as control. The coffee is compressed into a round 'cake' and water is pumped through the brewer. When the required amount of water has passed through the brewer, the now wet coffee 'cake' is squeezed, removing most of the water from the 'cake', preventing the brewer becoming unnecessarily dirty. After the 'cake' has been squeezed the brewer will deposit the cake into the dry waste container and return to the stand-by position.

Section 9 - Diagnostics and Maintenance Procedures

9.1 Diagnostics

The following pages list the error messages that may be displayed, diagnostics messages accessed via the engineers program and fault descriptions. For further help and advice please contact the Crane Merchandising Systems Technical Support Helpline on 01249 667323.

Error Message	Diagnostics Screen	Fault
Sorry Out of Service Head Not Homed	Head not homed	Dispense head has not returned to home position in expected time
Sorry Out of Service Head Not Extended	Head not extended	Dispense head has not fully extended in the expected time
Sorry Out of Service Waste Bucket Full	Waste bucket full	Waste bucket full
Temporarily Out of Service	Init failed restart	Machine failed on initialisation
Sorry Out of Service No I/O Comm	No I/O comm.	Comms error detected between mpu and I/O board
Initialising		CoEx® brewer not situated correctly in the machine
Temporarily Out Of Service	All selections disabled	All drink selections have been disabled
Sorry Out of Service Rinsing	Rinsing	Automatic or manual rinse cycle in progress
Out Of Cups Please Insert Mug	Cup turret/no cups/ no cups	Unable to find cup stack. Cup turret has timed-out on initialisation
Sorry Out of Service No Cups	No cups and mug sensor failure	Machine is out of cups and mug sensor is faulty
Out Of Cups Please Insert Mug	No cups/no cups	No cups are available but the mug sensor is working
Out Of Cups Please Insert Mug	No cup delivered ring 1 SV on	Non fatal error detected with SureVend cup mechanism
Please Remove Cup	Mug sensor error/please remove cup	An error has occurred with the SureVend sensor during a vend
Sorry Out of Service Mug Sensor Error	SureVend error and must SureVend	No cups remaining and fault with mug sensor

Error Message	Diagnostics Screen Text	Fault Description
Please Remove Cup	Mug sensor error	Cup not removed from dispense area after vend completed or faulty mug sensor
Sorry Out of Service Please Insert Mug	No cup delivered ring 1 SureVend on/SureVend error and must SureVend	Problem with CDU (cup jam) No more cups being dispensed
Sorry Out of Service Low water	Low Water	Low water level in heater tank
Sorry Out of Service Water Tank Heating	Water tank heating	Water in the heater tank is below the minimum vend temperature
Sorry Out of Service Fill Timeout	Fill timeout/ low water	Machine has been filling for 2 minutes and not reached optimum level
Sorry Out of Service Invalid Temp	Invalid temp	<ol style="list-style-type: none"> 1. Comms error between I/O & MPU 2. Machine has exceeded optimum boiler temp 3. Temperature probe fault
Sorry Out of Service Brewer Jam	Brewer jam	Brewer has not moved from its home position and may be jammed
Sorry Out of Service Brewer Not Homed	Brewer not homed	Brewer has not returned to its home position and may be jammed
Sorry Out of Service No Monetary Device	Coin mech comm	Communication error detected between monetary device and machine
Sorry Out of Service No Monetary Device	No monetary device- fatal/ No monetary device	Machine is configured for an incorrect monetary device, or the device is not responding
Temporarily Out Of Service	Coin mech ROM	MDB coin mech ROM checksum test failed (fatal error)
Temporarily Out Of Service	Coin mech accept unplugged	MDB coin mech is unplugged or faulty
Temporarily Out Of Service	Coin mech accept jam	Coin jam detected in coin acceptor
Temporarily Out Of Service	Coin mech payout jam	Coin jam detected in coin tube
Temporarily Out Of Service	Coin mech tube sensor	Coin tube sensor fault detected

Error Message	Diagnostics Screen Text	Fault Description
Temporarily Out Of Service	Coin mech all tubes error	No useable coin tubes. Machine unable to pay out
Temporarily Out Of Service	Coin mech tube error	Problem with coin tube. Tube indicates full, but coin count is zero
Temporarily Out Of Service	Card reader comm	Fatal error. Cannot communicate with the card reader
Temporarily Out Of Service	Single card reader error	Transient error with card reader, but card reader in service. Unable to communicate with the card reader
Temporarily Out Of Service	Card reader reports a comm error	Repeatable error with card reader, but card reader in service. Unable to communicate with card reader
Temporarily Out Of Service	Card reader error	Problem with card reader. Manufacturing error detected
Temporarily Out Of Service	Card reader failed OOS error	Card reader is out of service
Temporarily Out Of Service	Card reader reports comm error & is OOS	Comm error with card reader. Out of service
Temporarily Out Of Service	Card jammed in card reader	Card jam
Temporarily Out Of Service	Card reader failure	Problem with card reader. Manufacturing error detected
Temporarily Out Of Service	Card reader requests servicing	Card reader needs servicing
An Error has occurred		Low water during a CoEx® brewer clean
Sorry Out Of Service No Water Available	No Water Available	No Water Available (B2C Machines Only)
Sorry Out of Service Water Tank Leak	Water tank leak	The dispense valve is leaking

9.2 Heater Tank De-Scale Procedure

To maintain correct water levels and water temperature the heater tank must be inspected regularly and, if necessary, be de-scaled. To ensure long and trouble-free operation, Crane Merchandising Systems recommend that all machines have a water filter fitted. We recommend and supply the Brita AquaQuell Compact water filter.

There are a number of ways of de-scaling the heater tank. The tank can be removed and scraped out with a blunt tool but it can also be left inside the machine and a de-scaling agent introduced into the tank. Always remember to fit a new water filter and boiler seal after de-scaling.

Use the following steps as a guideline only and always refer to the instructions supplied with the de-scaling agents regarding dosage and de-scaling time.

1. Switch off the machine and open the door. Remove all canisters and back covers.
2. Using the drain hose fitted to the tank, remove the bung and drain the water from the heater.



Safety First! Allow the water in the tank to cool before draining.

3. Once all of the water has drained from the tank, replace the bung into the drain hose. Introduce the de-scaling solution in the recommended dosage into the heater tank on the machine and allow the heater tank to fill.
4. Turn off the machine and leave for approximately 40 minutes before draining the tank again following the sequence described above.
5. Fit a new water filter and switch on the machine. Fill the tank and drain again until all traces of the de-scaler are removed (at least 3 times).
6. Switch on the machine and allow the heater tank to fill and to heat up. Drain and fill one more time. The machine is now ready to be put back in service.

9.3 System Drain Down - B2C Machines Only

Should it become necessary for the engineer to do any work on the B2C water system it is very important that the following sequence is followed to ensure safe working as well as correct system fill and heating when the machine is powered up.

9.3.1 Cooling down the B2C system

1. Open the front door of the machine. Using the service keypad located in the rear of the door, press the 'Machine Cool Down' button (10) to ensure the system is cooled. Approximately 400ml of cold water is flushed through the system and out to the waste bucket.

Important: Pressing button 10 also informs the machine software that the B2C system has been drained ensuring that the B2C system will automatically fill before heating on power up. This is very important and must not be overlooked.

2. Once the B2C system has been cooled the LCD will display the message 'Machine cooled' and water will stop pumping through the system. Remove the waste bucket and empty the contents before re-fitting to the machine. Ensure all pipes etc are refitted correctly into the bucket.

3. Turn off the power to the machine.

9.3.2 Removing the module for maintenance

N.B. It is not necessary to remove the module to drain the system down.

To remove the module for maintenance, proceed as follows:

1. Close the fresh beans outlet slide and remove the fresh beans container along with the fresh ground coffee canister. Loosen the screws securing the RH boiler cover and remove. Unclip the two loom connectors to the B2C module.
2. Remove the brewer waste bucket from the machine. Turn off the water supply to the module using the cut off (1) located in water pipe situated under the module. Unscrew and remove the water inlet hose (2) to the module.
3. Loosen the two lower B2C module retaining screws. Carefully lift the module up and out of the machine.

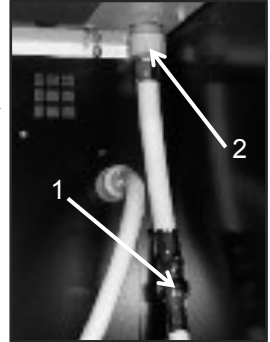

9.3.3 Draining down the module

Draining down the module allows the engineer to safely work on system components. It may also be necessary to do this for transit purposes.

N.B. A cool down cycle **MUST** be carried out before draining the module.

1. Remove the lower cover from the module to expose the boiler blanking plug (3). Hold the collar and remove the plug. Attach a length of silicone pipe to the outlet to act as a drain tube. Place the other end into a bucket.

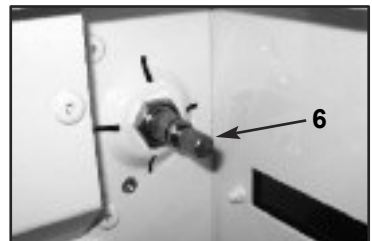
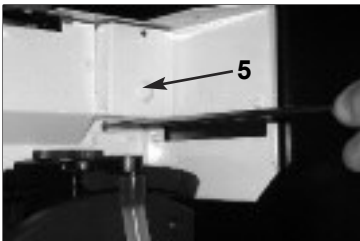
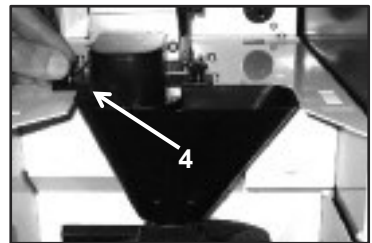
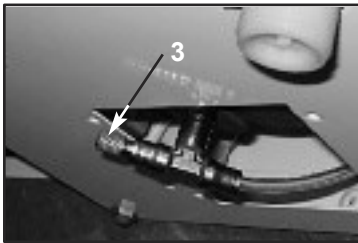

2. Remove the air intake cover (5) exposing the blanking plug. Access to this cover is made easier by first removing the B2C chute & cover (4). Remove the air intake blanking plug (6). Any remaining water will be ejected from the system.
3. Remove the drain tube from the outlet. Replace the blanking plug and lower cover. Refit the air intake blanking plug and cover. Replace the B2C chute and cover to the module.

9.3.4 Refitting the module and refilling the system

To refit the module and refill the system, proceed as follows:

1. Carefully re-install the module into the machine. Tighten the 2 lower module fixing screws and refit the top LH retaining screw, plug the two loom connectors into the module connectors and re-fit the water inlet hose.
2. Refit the RH boiler cover, fresh ground coffee canister and fresh beans container. Ensure fresh beans outlet slide is opened.
3. Before the machine is powered up it is important that any air is expelled from the system ensuring that the system is fully primed and free of any air pockets. Remove the water tray from the B2C module in order to gain access to the 3 bar valve shut off lever. Pull the lever down to open the valve.
4. Turn the power on to the machine, it will initialise, priming the system with 400ml of water before returning to standby. Hold a suitable container under the valve outlet during machine power up to collect any water ejected from the valve. Once in standby mode the valve shut-off lever should be closed. Place the brewer waste bucket into the machine and re-fit the water tray to the B2C module. Remove the safety key and close the door.



9.4 CoEx® Brewer/Bean Grinder Maintenance - B2C Machines Only

Espresso machines are fitted with the unique CoEx® brewer unit which produces both fresh coffee and espresso based drinks from ground beans and freshbrew pre- ground coffee from the same unit. Routine cleaning and maintenance instructions for this unit can be found in the Voce Operators Manual - Part No. PR10908000.

9.4.1 CoEx® Brewer/Grinder Blades - 50,000 Vend Service

Crane Merchandising Systems recommends that the brewer unit and bean grinder is serviced by an authorised engineer after every 50,000 vends.

A CoEx® service kit (part no. PH11705000, shown opposite) is available from the manufacturer and contains all of the components required to ensure the machine continues to give trouble-free service.

The service kit contains the following components (with part nos.):

1. Lower piston and cylinder assembly – Pt. No. ME10592000
2. Filter head assembly - Pt. No. ME11703000
3. Grinder blades - Pt. No. ME07308000
4. 'O' ring - water inlet (not shown) - Pt. No. ME10595000



To carry out the 50,000 vend service, proceed as follows:

1. Disconnect the machine from the mains electricity. Open the front door of the machine.
Remove the coffee dispense pipe from the brewer outlet.
Holding the unit as shown in the photograph, lift the green lever (a) and carefully pull the brewer unit out of the machine.

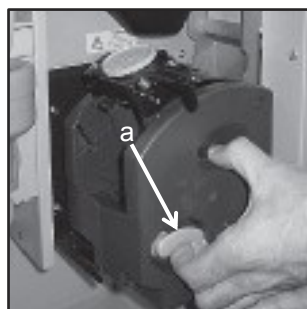

- Carefully unclip the wiper arm from the brewer unit and place to one side.

Remove the filter assembly from the brewer. Holding the filter assembly as shown, turn the locking ring anti-clockwise to its open position, indicated by the two arrows.

Carefully remove the old filter unit down and out of the CoEx® brewer unit. Discard the used filter unit.



- Remove the bolt securing the brewer drive coupling to the input shaft. Pull the coupling off of the shaft and place to one side.

Ensure that the captive lock nut is retained in the drive coupling moulding.

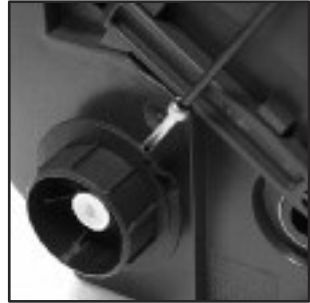

- Working from the front of the brewer, unscrew and remove the three retaining screws which secure the brewer unit together.

Carefully ease both the front and rear brewer panels away from the central piston chamber/swing arms assembly.

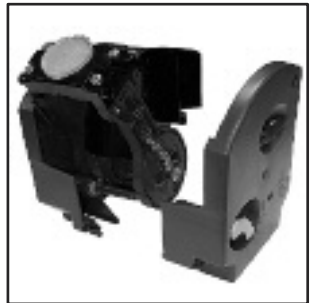

- Holding the unit as shown in the photograph, rotate the lower piston and cylinder assembly clockwise and then remove it up and out of the swing arms/filter holder assembly.

Discard the used lower piston and cylinder assembly.

Clean all of the dismantled brewer components thoroughly to remove all traces of waste coffee product.



6. Take the new lower piston and cylinder assembly from the service.
Before assembling the unit to the swing arms/ filter holder assembly, ensure that the lower piston (a) is at the top of its stroke as shown in the photograph.

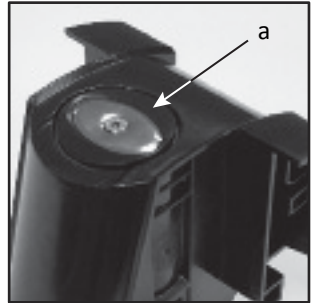

7. Ensure that the piston drive cam (b) is positioned as shown.
If necessary, push the piston drive cam anti-clockwise until it reaches its stop position.

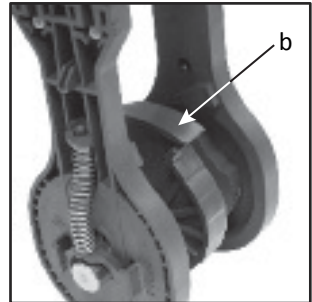

8. Holding the lower piston and cylinder assembly as shown, guide the assembly into the swing arms/ filter holder assembly.



9. Check and ensure that the lower piston guide block (c) locates with the piston drive cam (d) as shown in the photograph.

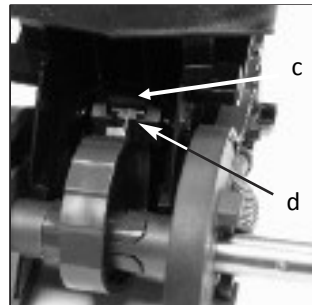

10. Ensure the plastic washer (a) if fitted is placed correctly over the input shaft (long side) as shown.

Re-assemble the front and rear brewer panels to the central piston chamber/swing arms assembly using the three retaining screws/locknuts. Check and ensure that the brewer release lever mechanism operates correctly.

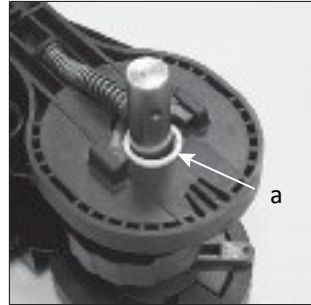

11. Re-fit the brewer drive coupling to the input shaft ensuring that the raised 'pip' (b) lines up with its locating dimple (c) on the input shaft.

Ensure that the captive lock nut is retained in the plastic drive coupling moulding. Refit the bolt to secure the brewer drive coupling to the input shaft.

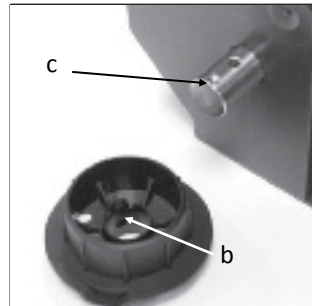

12. Take the new filter head assembly from the service kit.

Holding the new filter assembly as shown, turn the locking ring anti-clockwise to its open position, indicated by the two arrows.

Place the filter unit up into the filter holder and turn the green locking ring clockwise to lock it into place.

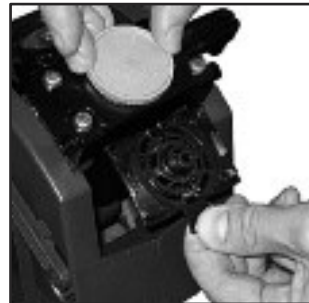

13. Re-assemble the wiper arm (d) to the filter holder assembly.

Ensure that the wiper arm is located under the coffee outlet pipes as shown (e).

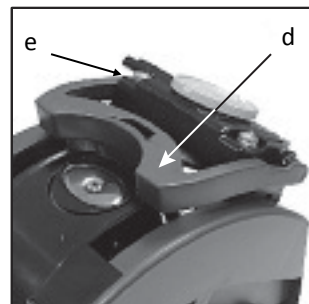

14. Moving to the machine, remove the 'O' ring (a) from the water inlet pipe and discard. Fit the 'O' ring included in the service kit onto the inlet pipe. Ensure that the new 'O' ring is seated correctly.
 Refit the CoEx® brewer unit into the machine. Slide the unit into place until it 'clicks' into position. Refit the coffee dispense pipe to the brewer outlet.

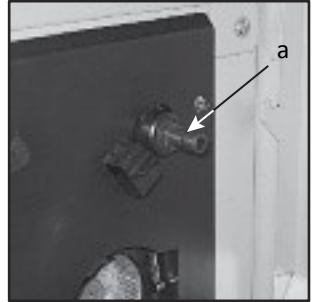

9.4.2 Replacing the Grinder Blades.

1. Isolate the machine from the Mains power supply.
 Push in the bean canister shut-off to close the fresh beans outlet. Carefully remove the fresh beans canister from the machine and place it to one side.

Pull up and remove the grinder adjusting wheel assembly (b) from the rear of the grinder body.

Unscrew the grinder body (c) anti-clockwise and remove it from the blade housing.

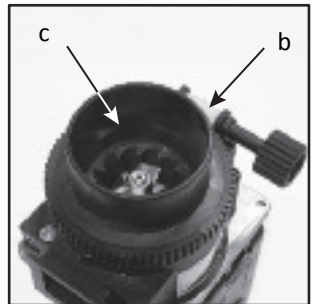

Note: Grinder mechanism removed from the machine for clarity.

2. Unscrew and remove the nut, star washer and agitator (d) from the drive shaft.

Note: Nut is fitted with a left hand thread. Remove the Grinder blade block (e) and discard. Replace with the new grinder blade block included with the service kit.

Refit the agitator, star washer and nut. Ensure that the nut is tightened securely.

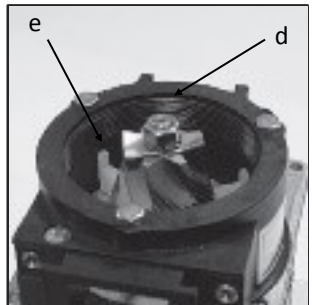

3. Take the new grinder body complete with inner grinder ring from the service kit. Screw the grinder body clockwise into the blade housing until it stops.

Re-set the grinder blades. An approximate starting position is achieved by turning the grinder body back one full turn anti-clockwise. Re-assemble the grinder adjuster wheel assembly to the grinder unit.

4. Refit the fresh beans container to the machine. Pull the bean canister shut- off to its fully extended position.
5. Turn on the electricity supply to the machine.

Important! Before returning the machine to service, the engineer must carry out the Grinder Calibration routine (refer to Section 6.5.15.1) to ensure correct operation of the grinder with the type of beans used in the machine. Use the grinder adjuster wheel to fine tune the blade settings in order to obtain the desired grind quality.

Section 10 - Electrical/Electronics Information

WIRE COLOUR	I/O BOARD		FUNCTION
	24V DC OUTPUTS		
Red/White	J3 1	H7 1	+24V DC
Pink	2	2	Inlet Valve (Hot Fill)
Grey/Green	3	3	Ingredient Motor 1
	4	4	
Blue/Yellow	5	5	Ingredient Motor 2
Green/Purple	6	6	Ingredient Motor 3
White/Yellow	7	7	Ingredient Motor 4
Orange/Yellow	8	8	Ingredient Motor 5
Black/Yellow	9	9	Ingredient Motor 6
Red/White	10	10	+24V DC
Violet/Red	11	11	Ingredient Motor 7
Pink/Black	12	12	Ingredient Motor 8
Grey/Pink	13	13	Whipper Motor 1
Blue/Pink	14	14	Whipper Motor 2
Green/Pink	15	15	Whipper Motor 3
White/Pink	16	16	Whipper Motor 4
White/Blue	17	17	Whipper 5 / Brewer Pump 1
Grey	18	18	Dispense Valve 1
No Pin	19	19	POLARISING PIN
Red/White	20	20	+24V DC
Grey/Violet	21	H8 1	Dispense Valve 2
Green	22	2	Dispense Valve 3
Yellow/Grey	23	3	Dispense Valve 4
Black/Red	24	4	Dispense Valve 5
White/Green	25	5	Dispense Valve 6
Orange	26	6	Dispense Valve 7
Purple/Red	27	7	Dispense Valve 8
Black/Pink	28	8	Whipper Motor 6 / FB Whipper Motor
No Pin	29	9	POLARISING PIN
Red/White	30	10	+24V DC
Purple/White	31	11	Turret Motor 1
Yellow/Orange	32	12	Carbonator Valve 1
Yellow/White	33	13	Still Valve 1
Yellow/Pink	34	14	Syrup Pump 1
Yellow/Blue	35	15	Syrup Pump 2
Yellow/Purple	36	16	Still Valve 2
Yellow	37	17	Cold Fill Valve / Water Pump
Yellow/Red	38	18	Brewer 1 Chamber Motor
Red/White	39	19	+24V DC
Green/Red	40	20	Ingredient Motor 9
Grey/White	41	H8A 1	Brewer 1 Belt Motor
Grey/Black	42	2	Autobar CDU 1 Peeler Motor
Red/Green	43	3	Brewer 2 Pump / Espresso Valve / Whipper 7
Orange/Red	44	4	Brewer 2 Chamber / Pressure Valve
Green/Orange	45	5	Brewer 2 Belt Motor / B2C Inlet Valve
Green/Blue	46	6	Stick Stirrer Solenoid
Red/White	47	7	+24V DC
	48	8	
	49	9	
	50	10	
	51	11	
	52	12	
	53	13	
	54	14	
	55	15	

Green/Yellow **EARTH STUD**

WIRE COLOUR	I/O BOARD		FUNCTION
	240V AC OUTPUTS		
	J10 1	H10 1	
	2	2	
	3	3	
Blue/Violet	4	4	
	5	5	Pump 1
	6	6	
Blue/White	7	7	Pump 2
	8	8	
Blue/Grey	9	9	Grinder Motor
	10	10	
	11	11	
Blue(1)	12	12	
	13	13	Neutral
	14	14	
	15	15	

I/O BOARD
24V DC HEATER O/P:

WIRE COLOUR	J8	H11	FUNCTION
Purple/Black	1	1	Solid State Relay 1 +ve
Violet/Orange	2	2	Solid State Relay 1 -ve
Purple/Green	3	3	Solid State Relay 2 +ve
Black/Grey	4	4	Solid State Relay 2 -ve

I/O BOARD
4V DC H-BRIDGE O/P

WIRE COLOUR	J9	H9	FUNCTION
Orange/Black	1	1	Dispense Head Motor 1 +ve
Red/Orange	2	2	Dispense Head Motor 1 -ve
Orange/Black(1)	3	3	
Red/Orange(1)	4	4	
White	5	5	Co-Ex Brewer Motor +ve
Orange/Pink	6	6	Co-Ex Brewer Motor -ve

I/O BOARD		SIGNAL INPUTS		FUNCTION
	J2	H13	1	
White/Red	2	2		Cold Fill Signal Input
Black/White	3	3		Common GND
	4	4		
Pink/White	5	5		Autobar CDU 1 Peeler Motor Switch
Red	6	6		Flow Meter +5V
Yellow	7	7		Flow Meter Signal Input
Black	8	8		Flow Meter GND
Red	9	9		Dispense Head 1 Sensor +5V
Yellow	10	10		Dispense Head 1 Sensor input
Orange	11	11		Dispense Head 1 Sensor GND
Red	12	12		CDU1 Cup Sensor +5V
Green	13	13		CDU1 Cup Sensor Signal Input
Black	14	14		CDU1 sensor GND
Pink/Yellow	15	15		Brewer 1 Home Position Switch Input
Blue/Black	16	16		Dispense Head 1 Home Switch Input
Yellow/Black	17	17		CDU1 Carousel Position Switch Input
Red/Black	18	18		Brewer 2 Home Position Switch / Co-Ex Switch
	19		H17	1
	20		2	
	21		3	
Brown/White	22		4	Infinity Mug Sensor +5V
Brown/Orange	23		5	Infinity Mug Sensor Signal Input
Brown/Green	24		6	Infinity Mug Sensor GND
	25		7	
	26		8	
	27		9	
	28		10	
	29		11	
	30		12	
	31		13	
	32		14	
	33		15	

I/O BOARD		ATER LEVEL INPU1		FUNCTION
	J6	H12	1	
Orange/Green	2	2		Boiler Level Input
Yellow/Green	3	3		Boiler GND
Blue/Green	4	4		Waste Bucket 1 Level Input
Yellow/Green(1)	5	5		Waste Bucket 1 GND
	6	6		

CONSOLE BOARD		SWITCH INPUTS		FUNCTION
	J6	H11	1	
Yellow/Red	2	2		Door Switch Input
Black	3	3		Door Switch GND
	4	4		
	5	5		
	6	6		
	7	7		
	8	8		

I/O BOARD		24V DC POWER		FUNCTION
	J7	H6	1	
White/Red	2	2		+24V DC from SMPSU
No Pin	3	3		
White/Black	4	4		GND from SMPSU

I/O BOARD		SERIAL COMMS		FUNCTION
	J5	H14	1	
Screen	2	2		GND
Red	3	3		RXD
Blue	4	4		TXD
	5	5		

MPU BOARD		24V DC POWER		FUNCTION
	J3	H2	1	
	2	2		
	3	3		GND from SMPSU
	4	4		+24V DC from SMPSU

MPU BOARD		SERIAL COMMS		FUNCTION
	J8	H1	1	
	2	2		
	3	3		
	4	4		
Red	5	5		TXD
Blue	6	6		RXD
Screen	7	7		
	8	8		GND

MPU BOARD		ANALOGUE INPUT:		FUNCTION
	J4	H3	1	
	2	2		
	3	3		
White	4	4		Thermistor 1 COM
Black	5	5		Thermistor 1 OUT
White	6	6		Thermistor 2 COM
Black	7	7		Thermistor 2 OUT
	8	8		
	9	9		

Section 11 - Dispense Pipe Lengths

There are two sizes of pipe used on a Voce machine which can be replaced by the Operator.

- CoEx outlet – 8mm x 13mm
- All others 6mm x 10mm

11.1 To replace pipes

1. Open cabinet door and extend the delivery head by pressing 8 on the service keypad.
2. Using the above information about pipe size connect the pipes to the dispense head; the numbers on the diagram below indicate which mixing bowl/ brewer should be connected to which nozzle.
3. The pipes should be cut to such lengths that when the head is in this extended position they are not too taut and neither does the pipe sag below the delivery head.

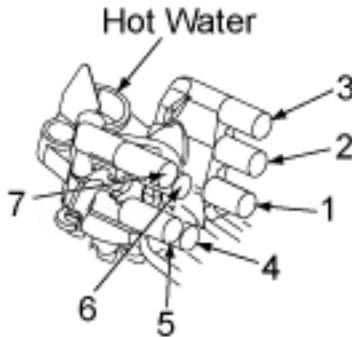

Section 12 - Spare Parts

The following section details the spare parts that are available for the Voce.

For all spare parts sales and enquiries:

Telephone: 01249 667321

Exterior View

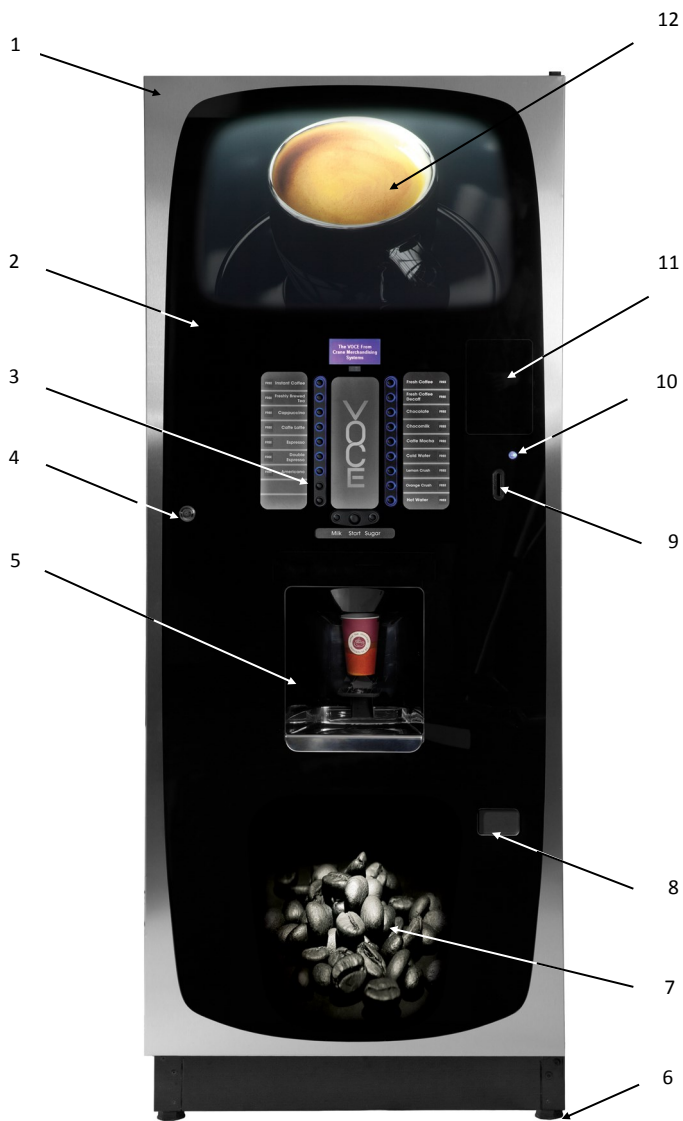

Exterior View Parts

Ref No.	Part No.	Item Description
1	MT13807130	Door Surround
2	GL13772000	Glass
3		Keypad Assembly (See page 108)
4	ME13870000	Door Lock
5		Dispense Area Components (See page 105)
6	ME13244000	Adjustable Foot
7	GR1381000	Lower Graphic Panel
8	PL13140000 + ME13141000	Reject Flap
9	PL13780000	Coin Insert
10	PL13786000	Reject Button
11	TBA	Card/Key Plate
12	GR13809000	Upper Graphic Panel
	PL13162000 + ME13141000	**Free Vend Reject Blanker
	PL13837000	**Free Vend Coin Insert Blanker

Interior View – Instant 8 Canister

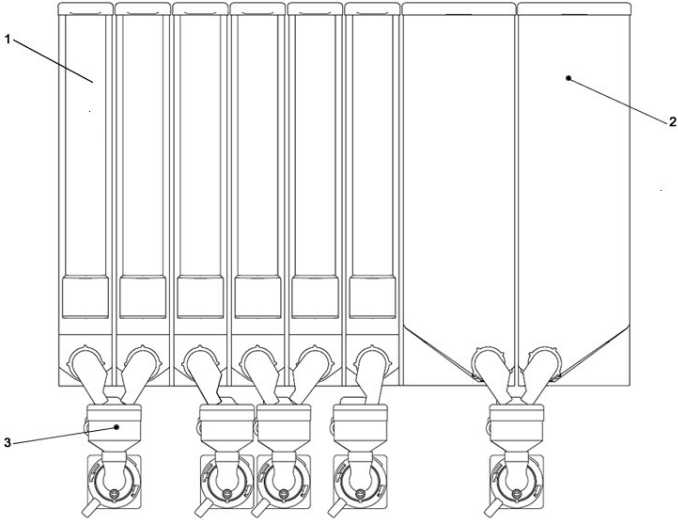

Ref No.	Part No.	Item Description
1		Canister Assembly (See pages 130 to 134)
2		FB Canister Assembly (See pages 130 to 134)
3		Mixing System (See pages 116 to 119)

Interior View – Single Freshbrew

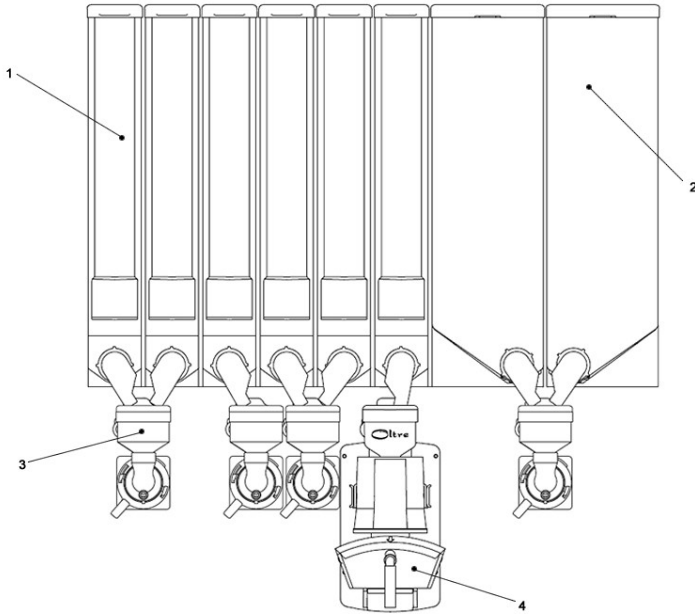

Ref No.	Part No.	Item Description
1		Canister Assembly (See pages 130 to 134)
2		FB Canister Assembly (See pages 130 to 134)
3		Mixing System (See pages 116 to 119)
4		Oltre Brewer (See page 121)

Interior View – Double Freshbrew

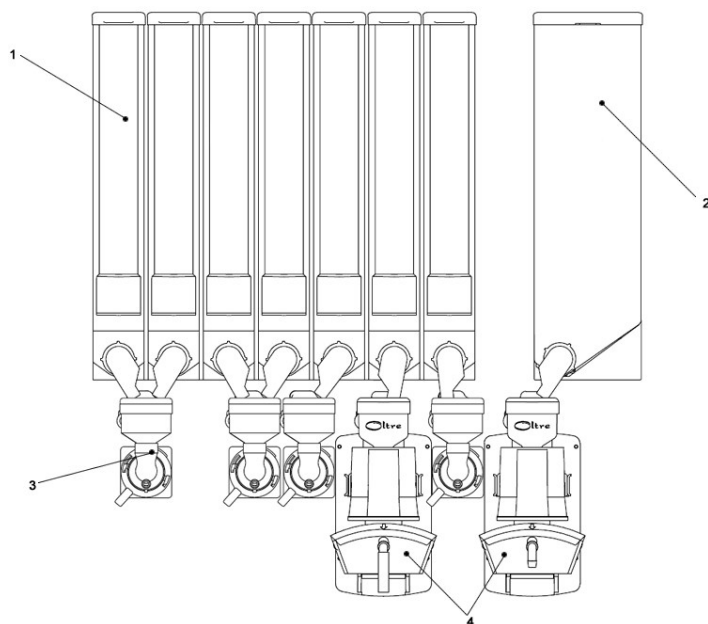

Ref No.	Part No.	Item Description
1		Canister Assembly (See pages 130 to 134)
2		FB Canister Assembly (See pages 130 to 134)
3		Mixing System (See pages 116 to 119)
4		Oltre Brewer (See page 121)

Interior View – Triple Freshbrew

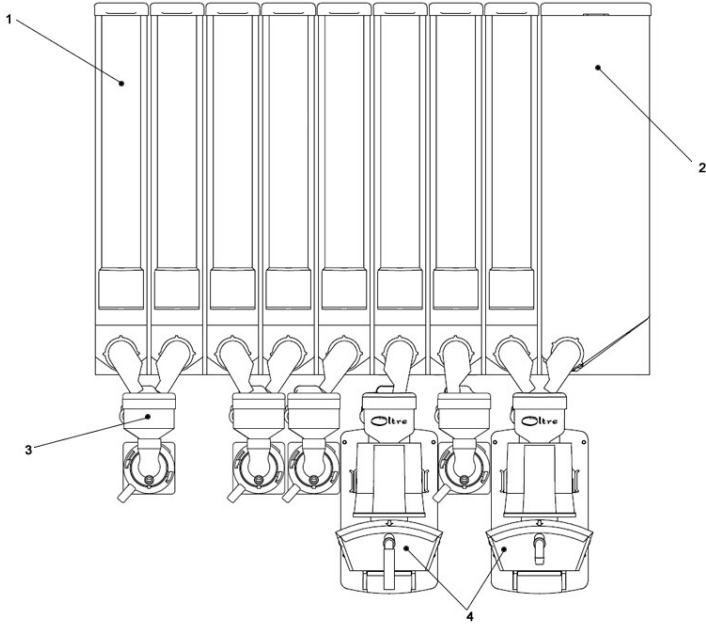

Ref No.	Part No.	Item Description
1		Canister Assembly (See pages 130 to 134)
2		FB Canister Assembly (See pages 130 to 134)
3		Mixing System (See pages 116 to 119)
4		Oltre Brewer (See page 121)

Interior View – Bean to Cup and Fresh Brew Tea and Roast and Ground Models

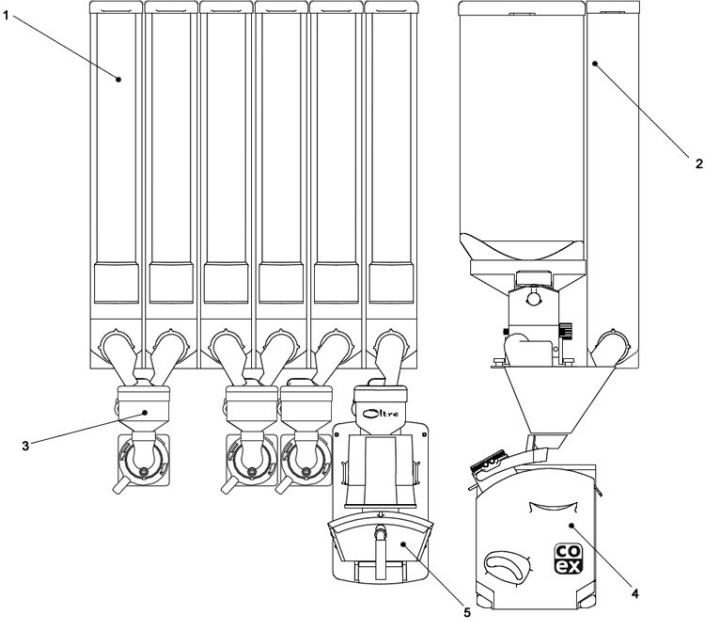

Ref No.	Part No.	Item Description
1		Canister Assembly (See pages 130 to 134)
2		Canister Assembly (See pages 130 to 134)
3		Mixing System (See pages 116 to 119)
4		CoEx Module Assembly (See page 123)
5		Oltre Brewer (See page 121)

Dispense Area Components

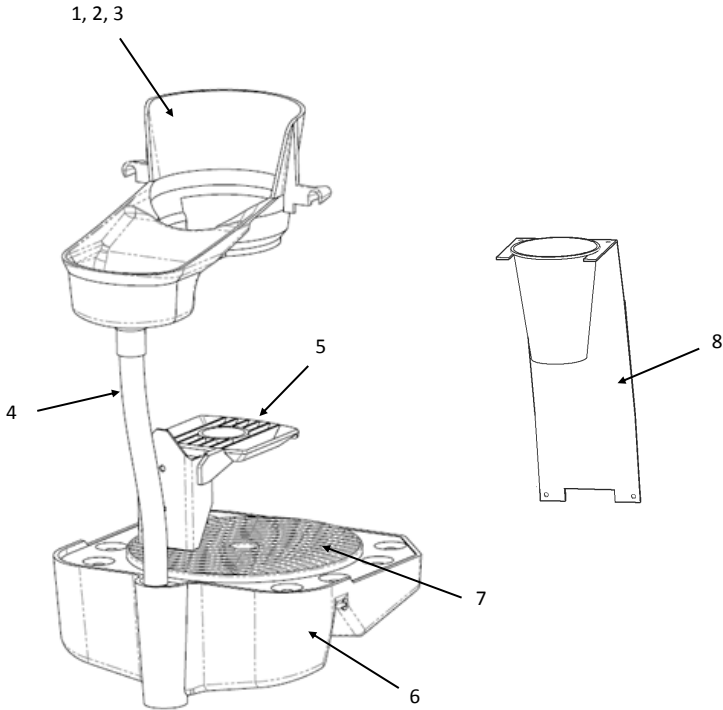

Ref No.	Part No.	Item Description
1	PL13126000	Cup Catcher Moulding - Squat Cup
2	PL13125000	Cup Catcher Moulding - Tall Cup
3	PL13128000	Cup Catcher Moulding - 12oz Cup
4	SI01142960	Silicon pipe - 16mm OD
5	PL04589000	Cup stand
6	PL13802000	Drip tray
7	PL10274000	Grille - drip tray
8	MT14064290	Drip Catcher Bracket

Dispense Head Assembly

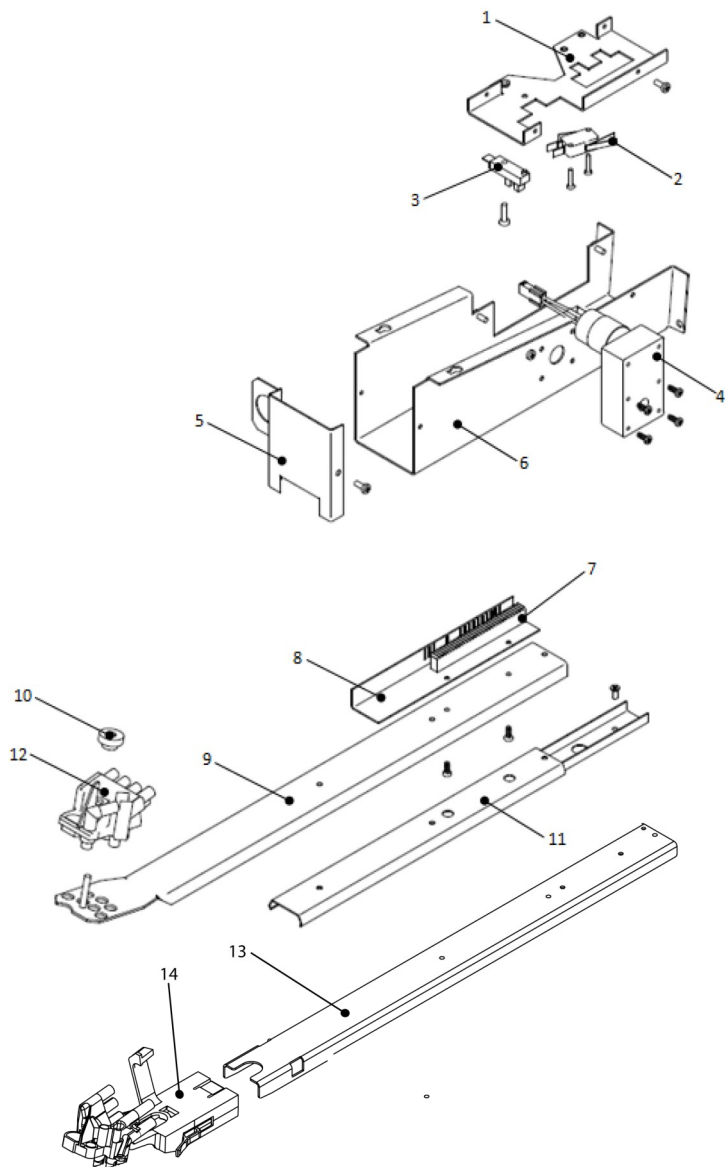

Dispense Head Assembly

Ref No.	Part No.	Item Description
	VO DISP HEAD	Complete Head Assembly
1	MT10695000	Dispense Head Channel
2	EL04920000	Micro Switch
3	EL10036000	Dispense Head Opto Device
4	MO10794000	Motor, 24Vdc, 50rpm
5	MT10696080	Dispense Head Front Cover
6	MT10694000	Dispense Head Body
7	PL10035000	Dispense Head Rack Moulding
8	MT10697000	Dispense Head Code Angle
9	MT13319000 (superseded by item 13)	Dispense Head Arm
10	FA01416000	M5 Nylon Thumb Nut
11	ME04063000	Dispense Head Slide
12	PL05496000 (superseded by item 14)	Dispense Head Moulding
13	MT13826250 (supersedes item 9)	Dispense Head Arm
14	PL13345000 (supersedes item 12)	Dispense Head Moulding
	PH05501000	Nozzle Set Moulded*
	LO11751000	Dispense Head Loom*

*Not Illustrated

Keypad – 18 Button

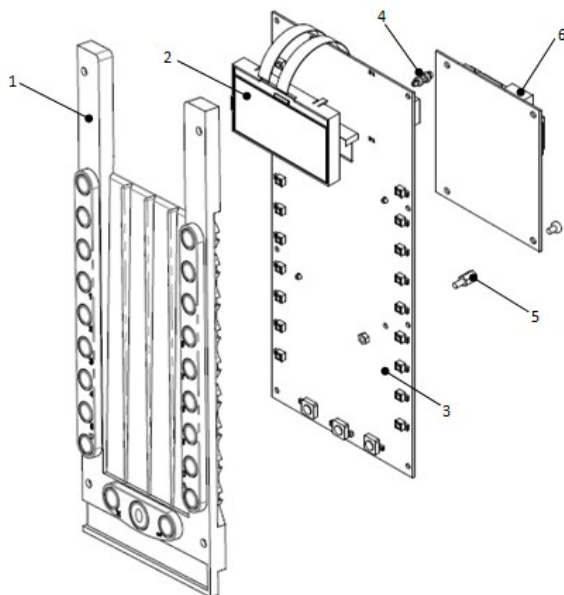

Ref No.	Part No.	Item Description
1	PL13777000	Keypad
2	EL10024000	LCD Display
3	EL10559001	Console PCB
4	FA10222000	PCB Stand Off
5	FA10223000	PCB Mount - Brass
6	EL10256000	MPU Board
	LO10225000	Link Loom – Console PCB to MPU*
	LO10958000	Link Loom – IRDA*

*Not Illustrated

Power Supply Assembly

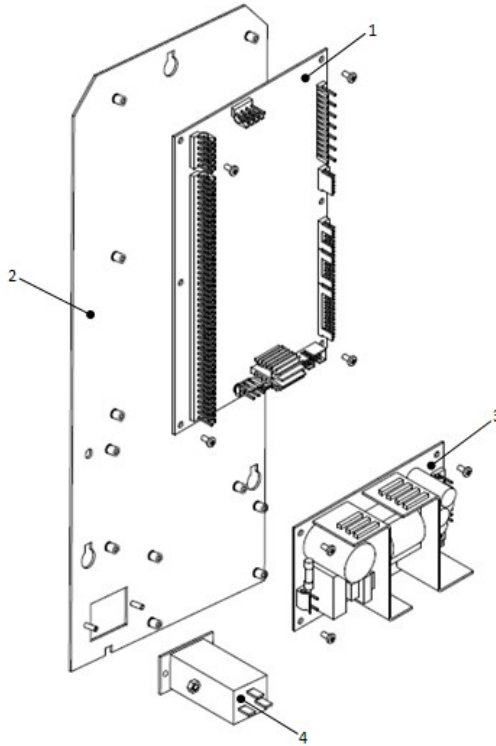

Ref No.	Part No.	Item Description
1	PH10534B2C	I/O Board
2	MT13514000	Plate
3	EL10021000	Switch Mode Power Supply
4	EL13175000	Mains Filter
	FA01519000	Edge Connector Board*

*Not Illustrated

Heater Tank Assembly

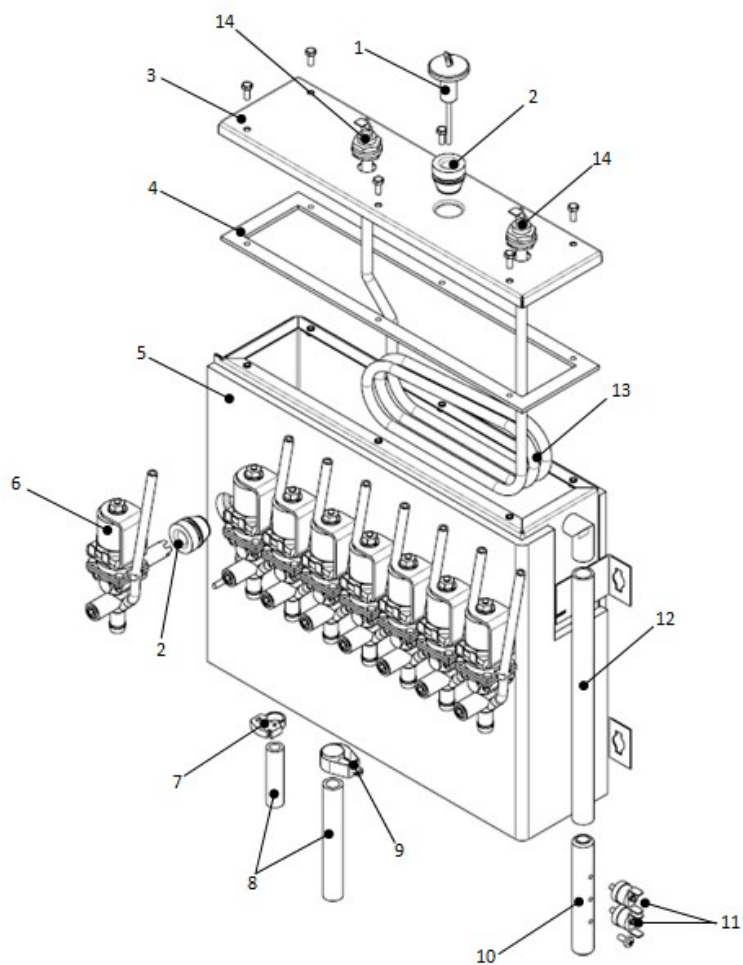

Heater Tank Assembly

Ref No.	Part No.	Item Description
1	ME04550000	Level Probe Assembly
2	VA03377000	Valve Seal
3	MT11998000	Boiler Lid
4	SI10627960	Heater Tank Seal
5	BA11996000	8 Port Boiler Assembly
6	VA10148000	Dispense Valve, 24Vdc x 8
7	FA01185000	Snapper Clip, 30
8	SI01171960	Silicon Pipe, 8mm ID
9	FA03227000	Unix Clip, 19mm
10	ME03024001	Temperature Cut-Out Holder
11	EL03378000	Temperature Cut-Out
12	SI01142960	Silicon Pipe, 12mm ID
13	EL11994000	Element 2.35 KW 240V

Cup Drop Unit Assembly

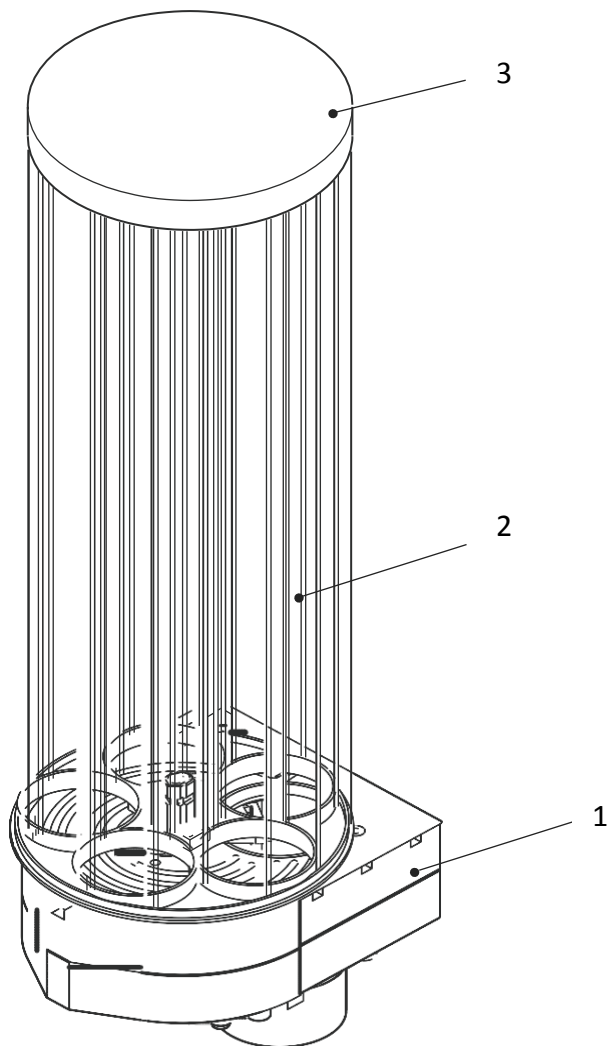

Cup Drop Unit Assembly

Ref No.	Part No.	Item Description
1	(a) ME11767000	Cup Drop Unit (Tall) - 70mm
	(b) ME11933000	Cup Drop Unit (Squat) - 73mm
	(c) ME13030000	Cup Drop Unit (12oz) - 80mm
2	(a) ME11768000	Turret Assembly - inc. 3(a)
	(b) ME13031000	Turret Assembly - inc. 3(b) - 12oz Model
3	(a) PL02713000	Lid (Cup Turret)
	(b) PL13113000	Lid (Cup Turret) - 12oz Model

7 Stack Cup Drop Unit Assembly

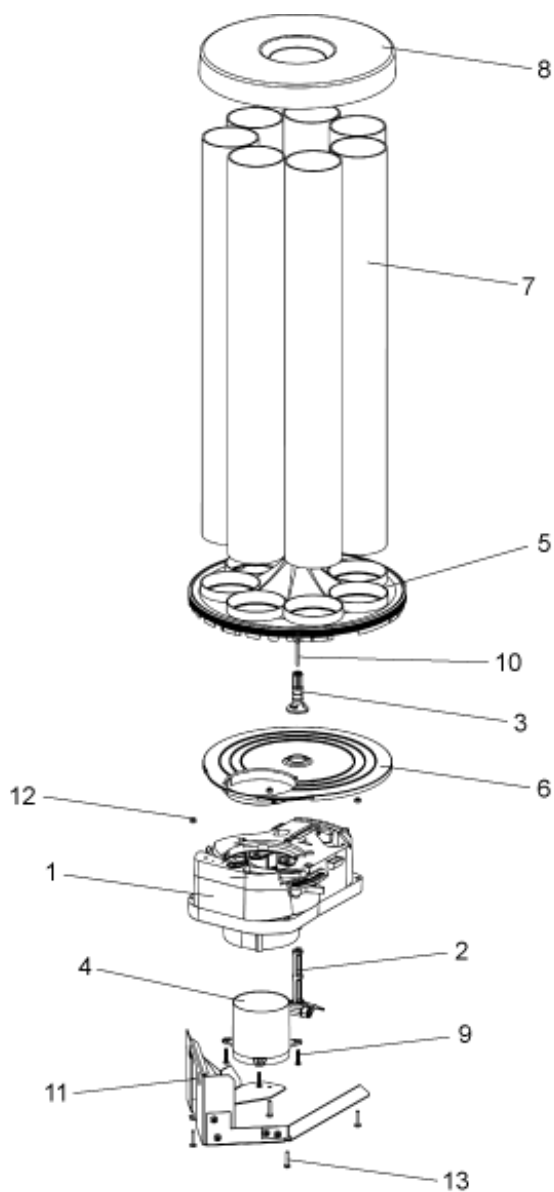

7 Stack Cup Drop Unit Assembly

Ref No.	Part No.	Item Description
1	ME14045	CDU Assembly
2	ME14046	Adjustable Pin Assembly
3	PL13692	Carousel Pin Top
4	PL13704	Cup Throat 70 / 73mm
5	PL13703	7 Stack Carousel 306mm
6	PL13702	Carousel Plate 306mm
7	PL13840	Turret Tube 70 and 73mm Cups
8	PL1839	Turret Lid 70 / 73mm
9	PL01973	PT Pan Screw M4 x 20
10	FA01118800	PZ Pan Screw M4x35
11	MT13871	CDU Mounting Bracket
12	FA03262000	Self-Locking Nut M4 Nyloc
13	FA13082000	PZ Pan Screw M4x20

Mixing System

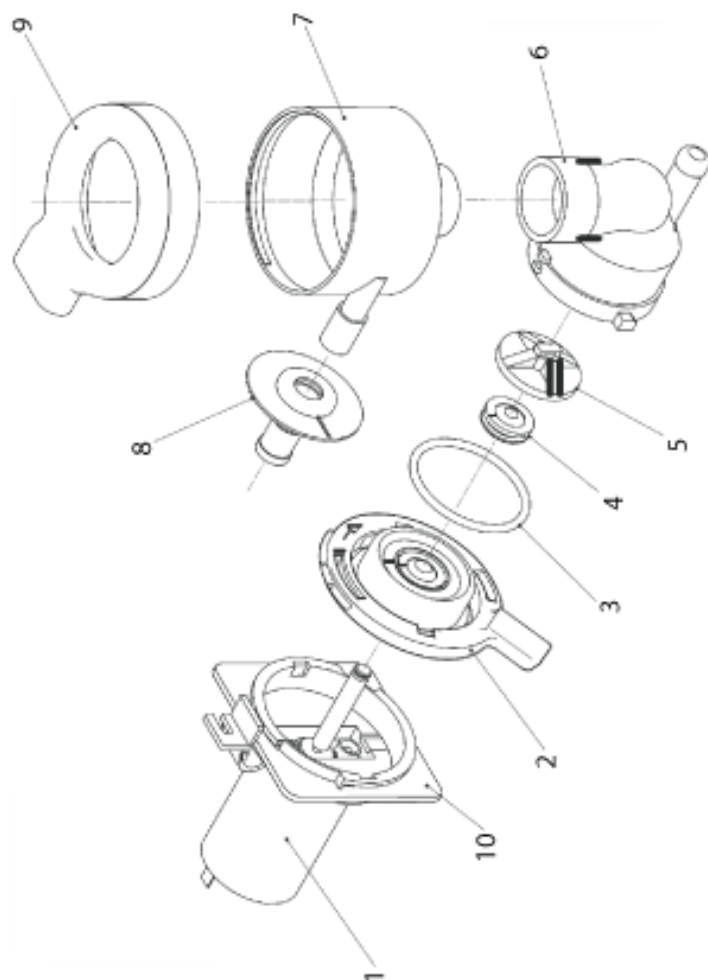

Mixing System

Ref No.	Part No.	Item Description
	VCH HYG TEA	VOCE Hygiene Tea Kit
	VCH HYG COF83	VOCE Hygiene Coffee83 Kit
	VCH HYG B2C	VOCE Hygiene Kit B2C
	VCH HYG B2C FBT	VOCE Hygiene Kit B2C+FBT
	VCH HYG DFB	VOCE Hygiene Kit DFB
	VCH HYG INSTANT	VOCE Hygiene Kit Instant
	VCH HYG R&G	VOCE Hygiene Kit R&G
	VCH HYG SFBC	VOCE Hygiene Kit SFB Coff
	VCH HYG SFBT	VOCE Hygiene Kit SFB Tea
	VCH HYG TFB	VOCE Hygiene Kit TFB
1	MO10991000	Whipper Motot 13K RPM 24V
2	PL10188001	Whipper Base Extended Arm
3	SI10343000	O Ring Whipper Base
4	SI10344000	Seal Whipper Base
5	PL01970000	Impeller GY
6	PL10992000	Whipper Body
7	PL01967000	Bowl Mixing Grey (INCL)
	PL13716000	Bowl Mixing DUAL INLET
8	(a) PL10183000	Bowl Adaptor
	(b) PL13504000	Bowl Mixing Bulkhead
9	PL10187000	Steam Trap
10	PL10802000 FA01134000	Whipper Mounting Plate Bowl Adaptor Seal*

* Not Illustrated

Crane Mixing System

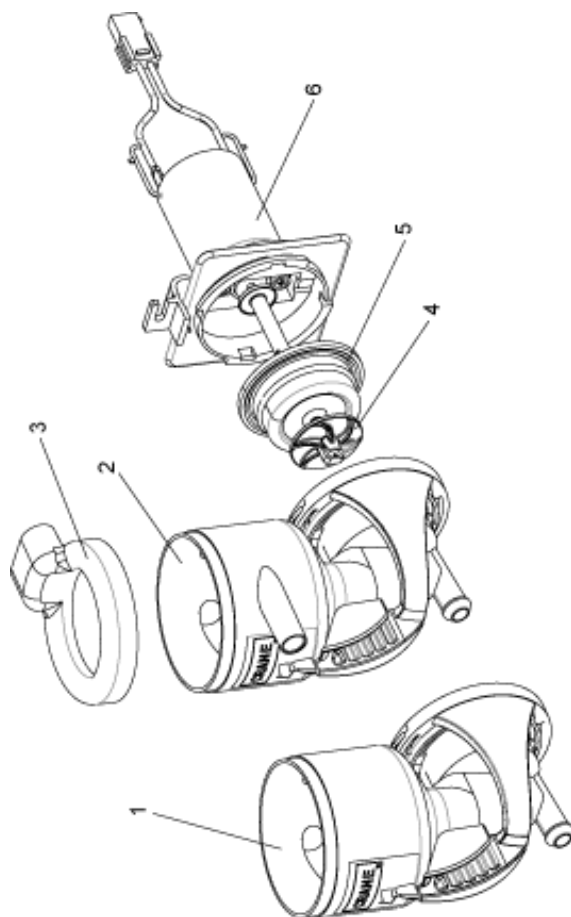

Crane Mixing System

Ref No.	Part No.	Item Description
1	ME14043	Whipper Bowl – Single Inlet
2	ME14044	Whipper Bowl – Dual Inlet
3	PL13725	Steam Trap
4	PL13723	Impeller
5	PL13728	Seal, Whipper Bowl
6	MO10991	Motor, Whipper

Oltre Brewer Fresh-Brew Tea and Fresh-Brew Coffee

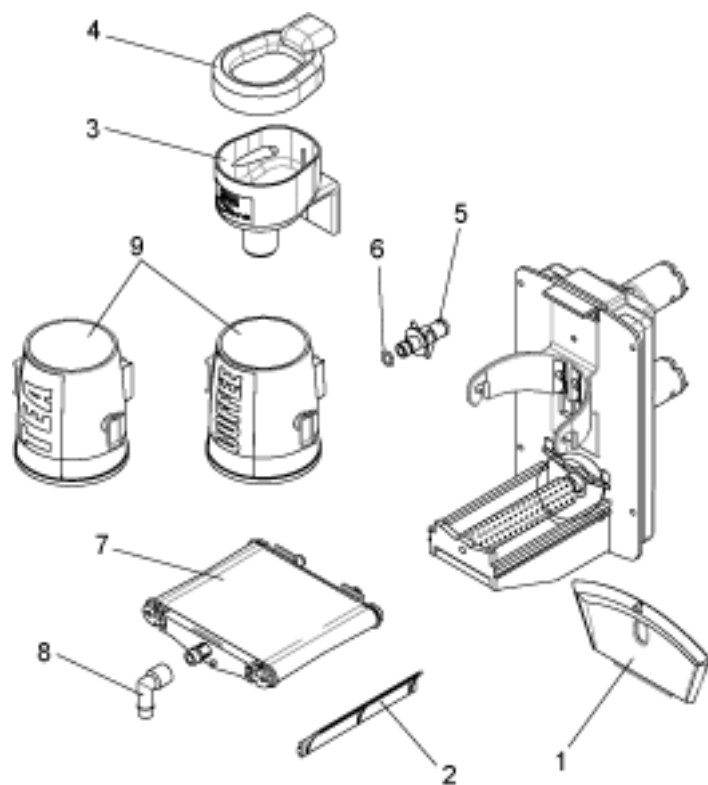

Oltre Brewer Fresh-Brew Tea and Fresh-Brew Coffee

Ref No.	Part No.	Item Description
	(a) ME13412	Coffee Brewer, EU
	(b) ME13414	Coffee Brewer, US
	(c) ME13413	Tea Brewer
1	PL134517	Release Handle
2	(a,b) PL134508	Cleaning Ribbon (Right Side Only)
	(c) PL1345010	Cleaning Ribbon (Right Side Only)
3	(a,b) PL1345514	Mixing Bowl
	(c) PL1345517	Mixing Bowl
4	(a,b) PL1345415	Steam Trap For Brewer
	(c) PL1345418	Steam Trap For Brewer
5	(a,b) PL1345616	Adaptor Crane
	(c) PL1345619	Adaptor Crane
6	(a,b) ME1343817	O-Ring For Outlet Plane Support Belt
	(c) ME1343820	O-Ring For Outlet Plane Support Belt
7	(a,b) ME1346518	Belt Filter Assembly ID73 Coffee
	(c) ME134668	Belt Filter Assembly ID73 Tea
8	(a,b) PL1347819	Spout ID6 For Coffee
	(c) PL134779	Spout ID4 For Tea
9	(a) PL1347420	Lower Chamber Assembly EU Coffee
	(b) PL1346920	Lower Chamber Assembly Coffee ID83
	(c) PL1353211	Lower Chamber Assembly Tea ID73

CoEx® Module Assembly (B2C Machines)

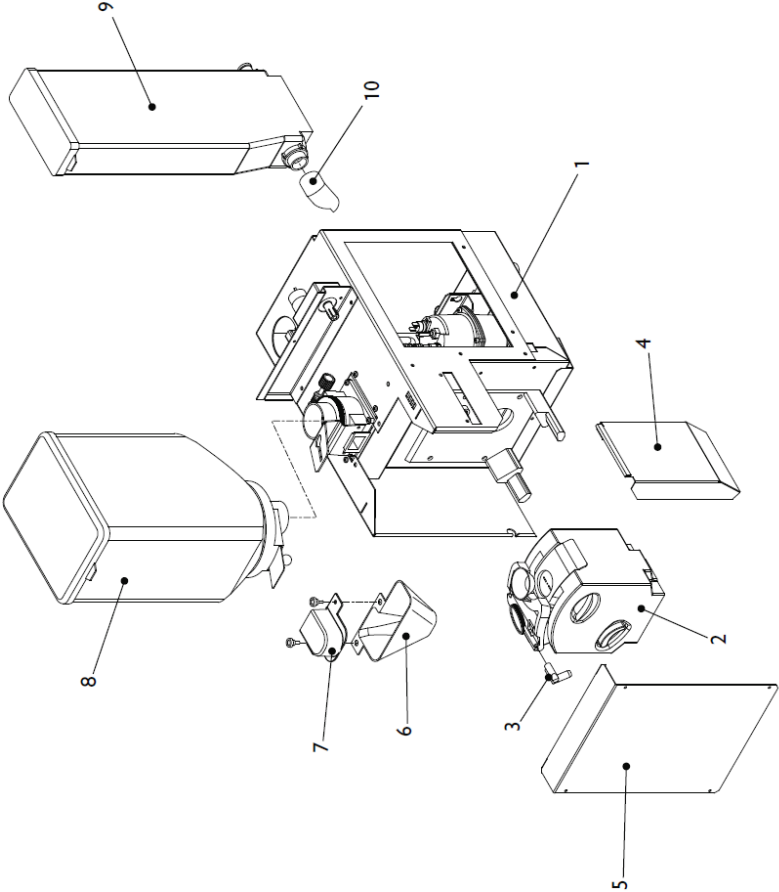

CoEx® Module Assembly (B2C Machines)

Ref No.	Part No.	Item Description
1		Module Assembly (See page 127)
2		CoEx® Brewer Assembly (See page 125)
3	PL10283000	CoEx® Brewer Spout
4	MT13323000	Side Tray Long
5	MT10847000	Brewer Cover
6	PL10580000	Grinder Chute
7	PL10282000	Grinder Chute Cover
8	PL10792000	Fresh Beans Canister c/w Lid
9	PL13971000	Freshbrew Canister
10	PL01442000	Freshbrew Canister Chute
	MT11655080	Cover, Drain*

* Not Illustrated

CoEx® Brewer/Motor Assembly (B2C Machines)

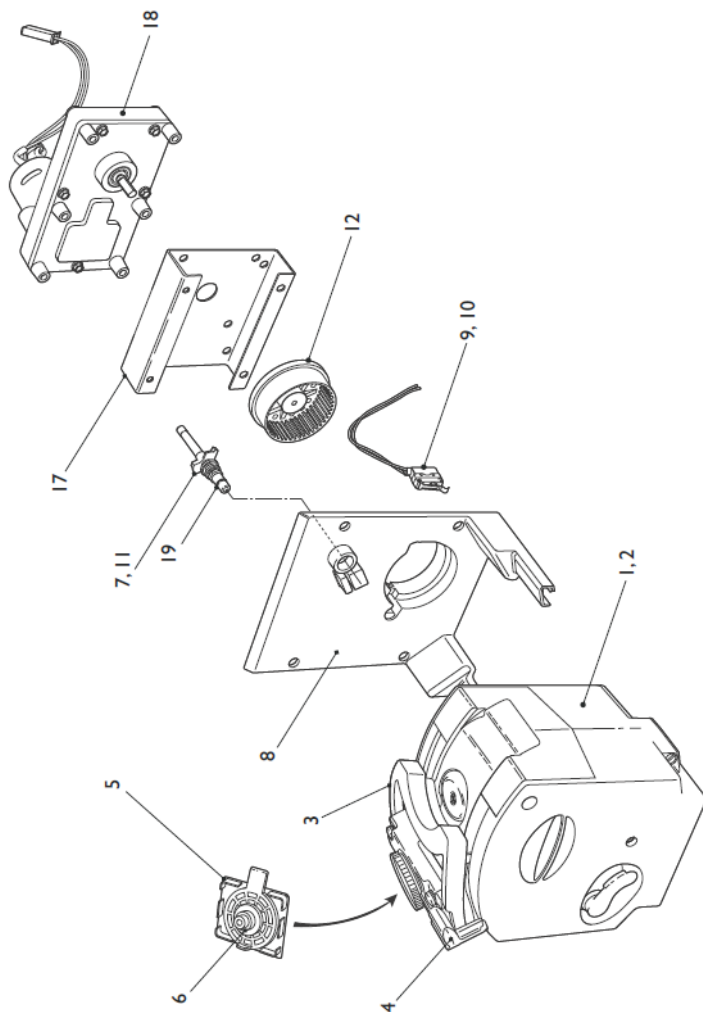

CoEx® Brewer/Motor Assembly (B2C Machines)

Ref No.	Part No.	Item Description
1	PH10190000	CoEx® Brewer Assembly + Filterhead
3	PL11622000	Wiper Arm
4	PL10283000	Coffee Outlet Spout
5	(b) ME10284000	Filter Head Assembly (Includes item 6)
6	ME10596000	Quad Ring
7	ME10595000	'O' Ring – Water Inlet Connection
8	ME10762000	Mounting Bracket
9	EL10903000	Microswitch, c/w Lead
10	EL10587000	Lever, Microswitch
11	ME10763000	Water Inlet Connection
12	ME10597000	Drive Wheel
13	(b) PH11705000*	Service Kit (Includes items 5, 7, 14 and 15)
14	ME10592000*	Lower Piston and Cylinder Assembly
15	ME07308000	Grinder Blades
16	(b) PH11683000*	Motor Assembly (Inc. items 12, 17 and 18)
17	(b) MT10978000	Motor Mounting Bracket
18	(b) MO11679000	CoEx® Brewer Motor
19	ME10595000	Seal
	ZC10598000	Cleaning Tablets (x30)

+ Includes items 2-5 and 7-12
* Not Illustrated

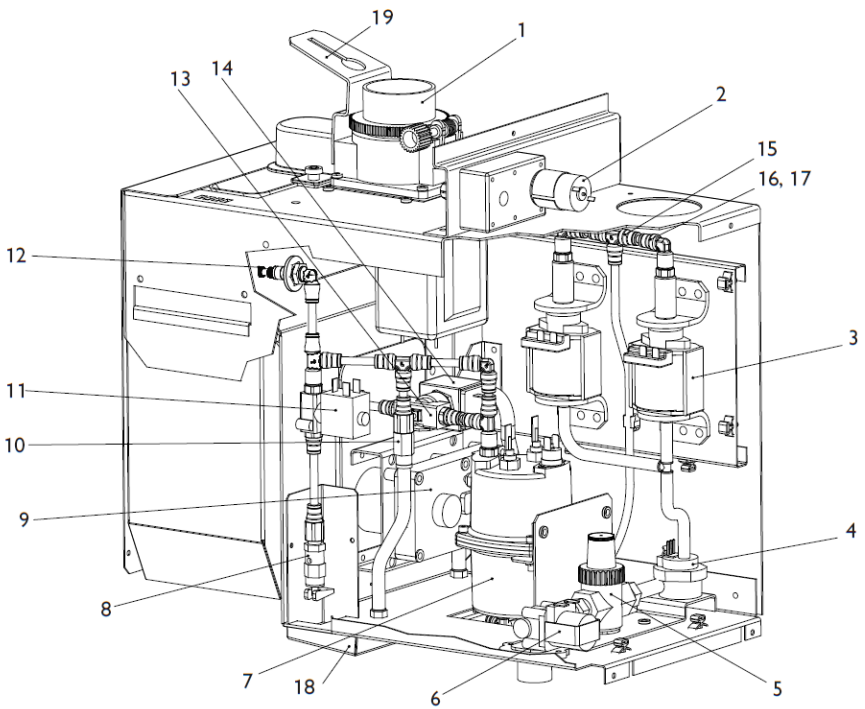





**CoEx® Module Assembly
(B2C Machines)**

CoEx® Module Assembly (B2C Machines)

Ref No.	Part No.	Item Description
	1 EVO B2C MOD	Module, New
1	MO10108001	Grinder, 230V
2	MO10152000	Ingredient Motor - 130rpm, 24V DC
3	ME10047000	Pump, 230V
4	ME10834000	Flow Meter
5	VA10048000	Pressure Reducing Valve, 0.5 Bar
6	VA13245000	Inlet Valve, 24V DC
7	BA10000000	Pressure Boiler Assembly
8	VA10044000	3 Bar Relief Valve
9	MO11679000	Brewer Motor, 24V DC
11	VA10042000	Espresso Valve, 2 Way
12	ME11186000	Drain Plug
13+14	VA11362000	Espresso Valve Body, 3 Way
15	ME10216000	'T' Shaped John Guest Fitting
16	ME10208000	'R' Shaped John Guest Fitting
17	HO10245000	FEP Pipe
18	MT10965000	Water Tray
19	MT10808000 ME07308000 ME11175000	Mounting Bracket Grinder Blades* Grinder Gear*

CoEx[®] Additional Parts - B2C Module Assembly

Ref No.	Image	Part No.	Item Description
1		ME10216000	Pressure Fitting Equal Tee
2		ME10211000	Pressure Fitting Female
3		ME11654000	Pressure Fitting Elbow
4		ME10212000	Pressure Fitting Male Tee
5		ME10207000	Pressure Fitting Tee
6		ME10208000	Pressure Fitting Elbow Male
7		ME11186000	Pressure Fitting End Stop
8		ME10220000	Pressure Fitting Tube
9		EL10058000	Temp Cut out 120 Deg
10		PL10246000	Tee Piece Nylon 6mm
11		ME10217000	Pressure Fitting Male
12		ME10217000	Pressure Fitting Equal Elbow
13		EL10228000	Boiler Thermistor Probe

Canister Assembly

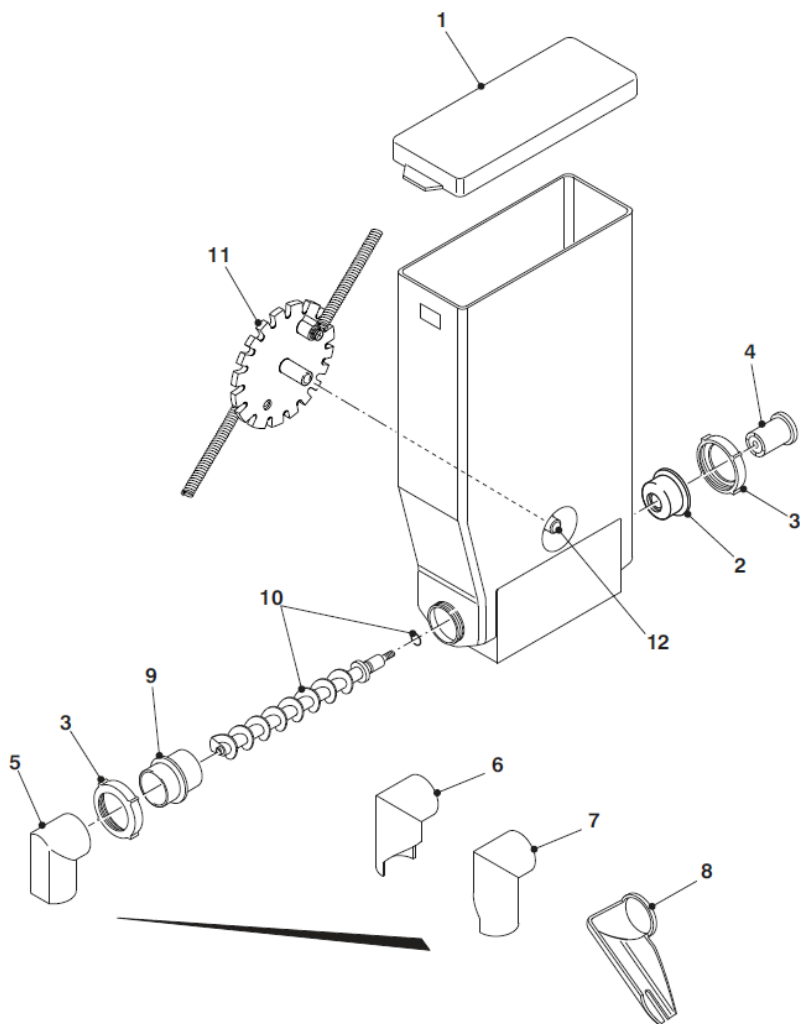

Canister Assembly

Ref No.	Part No.	Item Description
	PL11170000	Canister, 67mm wide (c/w agitator) - Freshbrew/Instant
	PL11608000	Canister, 67mm wide (no agitator) - Freshbrew/Instant
	PL11172000	Canister, 67mm wide (c/w agitator and stainless steel auger)
	PL10856000	Canister, 42mm wide (c/w agitator) – Freshbrew Coffee
1	PL11179000	Canister Lid, 67mm wide
2	PL10358000	Flange Rear
3	PL10356000	End Cap
4	PL02711000	Canister Drive
5	PL01128000	Canister Chute - Central
6	PL01441000	Canister Chute, LH - Long
7	PL01442000	Canister Chute, RH - Long
8	PL10297001	Extended Chute (B2C Tea Canister)
9	PL10357000	Flange - Front
10	(a) ME02706000	Auger (Plastic c/w 'O' Ring)
	(b) ME10386000	Auger S/S Wire 224 Series
	(c) SI02705000	O' Ring
11	(a) PL02707000	Agitator Assembly (Spring)
	(b) TBC	Agitator Assembly (Wire)

Canister Assembly – Freshbrew Coffee

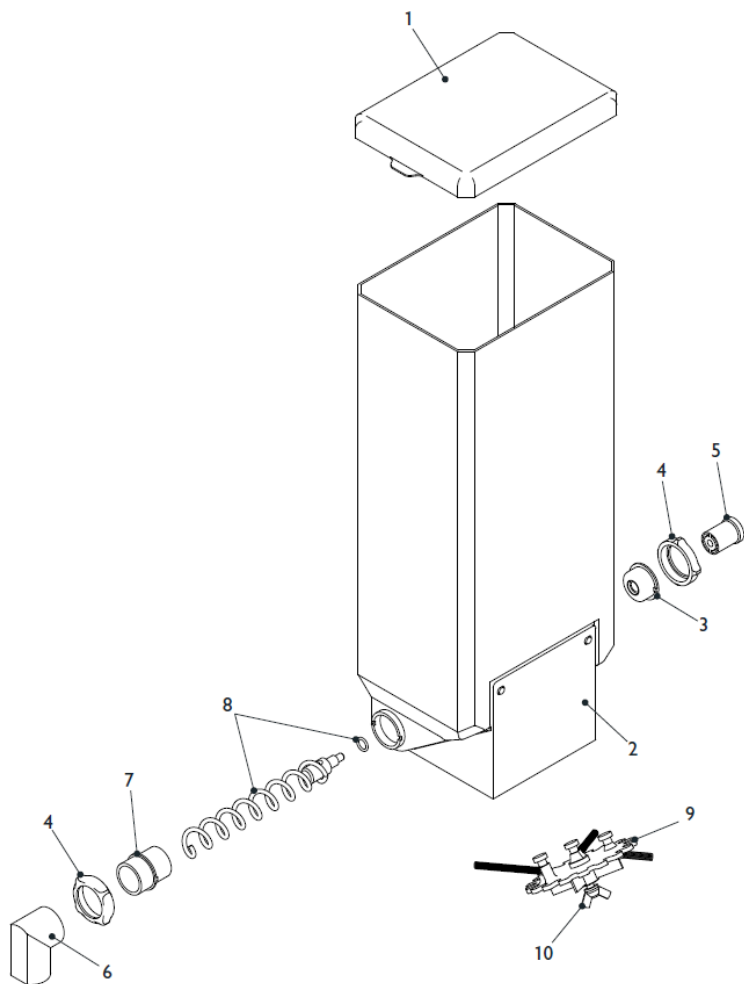

Canister Assembly – Freshbrew Coffee

Ref No	Part Number	Item Description
	PL10821000	Large Canister Complete (LH)
	PL13986000	Large Coffee Canister Complete (LH)
	PL13717000	Large Canister Complete (RH)
1	PL11180000	Canister Lid
2	(a) PL11181000	Canister Base (RH)
	(b) TBC	Canister Base (LH)
3	PL10358000	Flange - Rear
4	PL10356000	End Cap
5	PL02711000	Canister Drive
6	PL01128000	Canister Chute - Central
7	PL10357000	Flange - Front
8	(a) TBC	Auger, Plastic c/w 'O' Ring
	(b) TBC	Auger, S/S c/w 'O' Ring
	(c) SI02705000	'O' Ring
9	PL11182000	Agitator Assembly
10	PL11183000	Agitator Fixing Nut

Canister Assembly – Bean Hopper (Round)

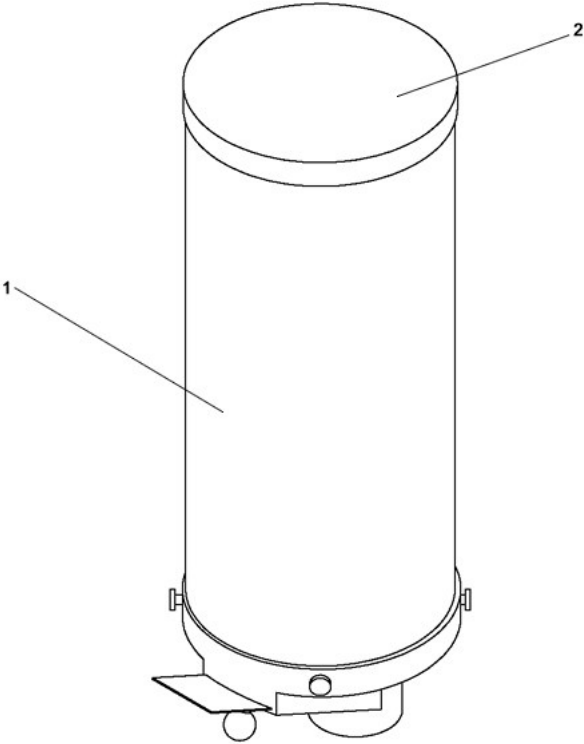

Ref No.	Part No.	Item Description
1	PL14258000	Bean Hopper Round
2	PL14339000	Lid, Bean Hopper Round

Surevend™ Assembly

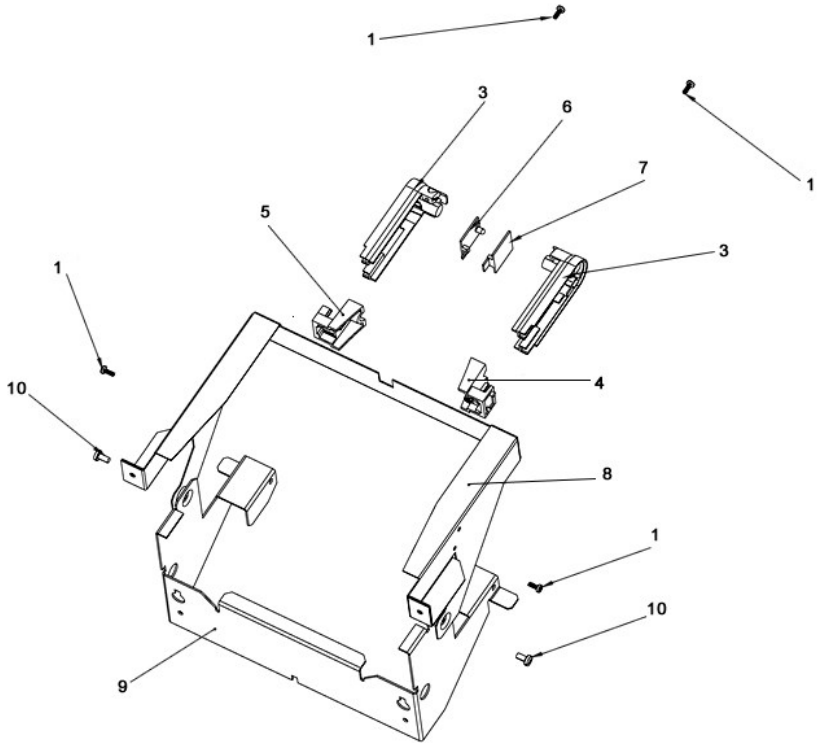

Ref No.	Part No.	Item Description
1	FA13304000	K40 X 10 PT Screw LN1452
2	PL13147000	Clip Cup CATCHER
3	PL13134000	LENS CUP SENSOR
4	PL13778000	SURE VEND PCB LOCATOR LH
5	PL13779000	SURE VEND PCB LOCATOR RH
6	EL13152000	PCB CUP SENSOR (PAIR) - LED
7	EL13152000	PCB CUP SENSOR (PAIR) - SEN
8	MT13790000	VEND AREA RETAINER
9	MT13796000	BRKT MNTG DRIP TRAY
10	FA04431000	M5X10 TAPTITE POZIPAN HD

Extract System

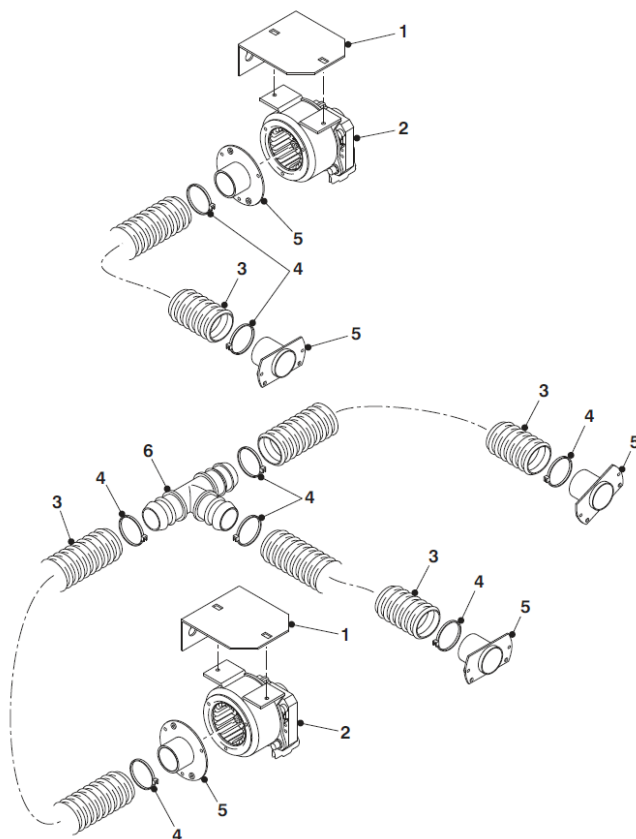

Ref No.	Part No.	Item Description
1	MT04132000	Mounting Bracket
2	ME10182000	Extract Fan
3	HO01139000	Hose
4	FA01188000	Cable Tie
5	PL03083000	Extract Hose Adaptor
6	PL04165000	'T' Piece - 11/4"

Waste Bucket

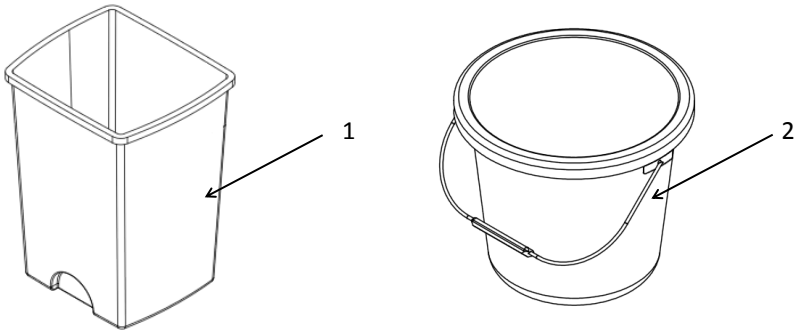

Ref No.	Part No.	Item Description
1	PL06672000	Bucket 24L FB Waste Grey
2	PL01172000	Silver Bucket 10L

Refrigeration Components

Ref No.	Image	Part No.	Item Description
1		VA11911000	Dispense Valve 24VDC
2		ME11912000	Syrup Pump Assembly 24VDC
3		ME11913000	Syrup Pump Tube
4		ME03072000	Water Pressure Regulator
5		ME10857000	Pump Aquatech
6		ME07238000	Agitator Assembly
7		ME03278000	Fan Unit Condenser
8		EL11915000	PCB Viscount MK4
9		VA07921000	CO2 Pipe Assy Carb

Additional Refrigeration Components – No Images

Part No.	Item Description
HO04997000	EVA Tubing 8mm OD
HO04989000	EVA Tubing 6mm OD
PL11004000	Bath Filler Assembly
PL08703000	3/8" Tube to Hose Stem
PL08702000	3/8" to 5/16" Elbow JG
PL12074000	5/16" Equal Connector Straight
HO06730000	5/16" to 1/4" Elbow JG
C3638147	5/16" to 3/8" Connector Straight
EL08784000	Compressor Start Capacitor
EL08985000	Compressor Start Relay
EL08786000	Compressor Thermal Cut out
D80492549	Fuse 1 amp 20mm
VA07921000	CO2 Pipe Assy Carb
ME06734000	CO2 Regulator ODL
ME02914000	Seal CO2 Regulator
ME13118000	Dispense Harness
ME08729000	Oetiker Clamp 7 to 8.7mm
ME08730000	Oetiker Clamp 8.8 to 10mm
EL01155000	Mains Filter 6 AMP
MT13548000	Mains Filter Mounting Plate
MT13549000	Mains Filter Cover

Fixings & Fasteners

Part No.	Item Description
FA10203000	M3 Nyloc Nut
FA01499000	M3 Nut Plain ZP
FA01498000	M3 X 6 Pozi Pan Screw
FA10205000	M3 X 10 Pozi Pan Screw
FA05206000	M3 X 16 CSK Screw
FA01503000	M3 X 16 Pozi Pan Screw
FA04422000	M4 Shakeproof Washer
FA01501000	M4 Washer Plain
FA01506000	M4 Hex Full Nut
FA03262000	M4 Nyloc Nut ZP
FA03289000	M4 Nyloc Nut Stainless
FA01506000	M4 X 6 Pozi Pan
FA02431000	M4 X 8 Pozi Pan Stainless
FA10807000	M4 X 10 Taptite screw
FA01504000	M4 X 10 Pozi pan
FA01143000	M4 X 10 Hex Bolt Stainless
FA07111000	M4 X 10 Thumb Screw
FA04304000	M4 X 16 Pozi pan
FA02029000	M4 X 20 Pozi Pan
FA04301000	M4 Skiffy Thumb nut

Part No.	Item Description
FA01507000	M5 Washer plain
FA01555000	M5 Washer ShakeProof SS
FA01508000	M5 Full Nut ZP
FA01683000	M5 Nyloc Nut ZP
FA13305000	M5 Flanged Nyloc Nut
FA01509000	M5 X 10 Pozi Pan Screw
FA04431000	M5 X 10 Taptite Screw
FA05210000	M5 X 10 Cheese Head Screw
FA01682000	M5 X 16 Pozi Pan Screw
FA10863000	M5 X 25 Carriage Bolt
FA01416000	M5 Skiffy Thumb Nut
FA01561000	1/4 ZP Plain Washer
FA01487000	Faston Connector 1/4"
FA01488000	Faston Connector Boot 1/4 "
FA01489000	Spade Connector 1/4"
FA14890000	Spade Connector Boot
FA01188000	Cable Tie Small
FA01860000	Cable Tie Medium
FA01189000	Cable Tie Holder
FA10222000	PCB Support
FA03227000	Unex Clip 19mm



Visit the **Tech Zone** on our website to find this and other manuals and technical information for the Crane range
www.cranems.co.uk/technical/

Pipsmore Park, Bumpers Farm Industrial Estate
Chippenham , Wiltshire, SN14 6NQ
Tel: +44 (0) 1249 444807 Fax: +44 (0) 1249 44819
Email: sales@cranems.co.uk
Website: www.cranems.co.uk